

COMMERCIAL SERIES

HARVEY

COMMERCIAL GLAZING SYSTEM

FABRICATION REFERENCE



"Building products beyond the standards"



TABLE OF CONTENTS

..... PG 4	Profiles
..... PG 19	Wedges and Seals
..... PG 20	Components
..... PG 23	Assembly Details
..... PG 27	Cross Sections
..... PG 45	Machining Details
..... PG 58	Performance Data

DISCLAIMER

Whilst best efforts have been made to ensure the details contained herein are accurate and correct, Wintec Systems is not responsible for any loss or damage whatsoever arising as a result of any errors contained in this manual. Interpretation of standards or codes within this manual is Wintec Systems interpretation of such codes. Responsibility for code compliance remains with the user of this manual. In some cases product specifications may vary without notice. Users should not act or rely upon any information contained in this manual without obtaining appropriate professional advice relating to their particular circumstances. To the maximum extent permitted by law Wintec Systems disclaims all liability for loss or damage suffered by anyone who acts or fails to act in reliance of this manual.

FRAME

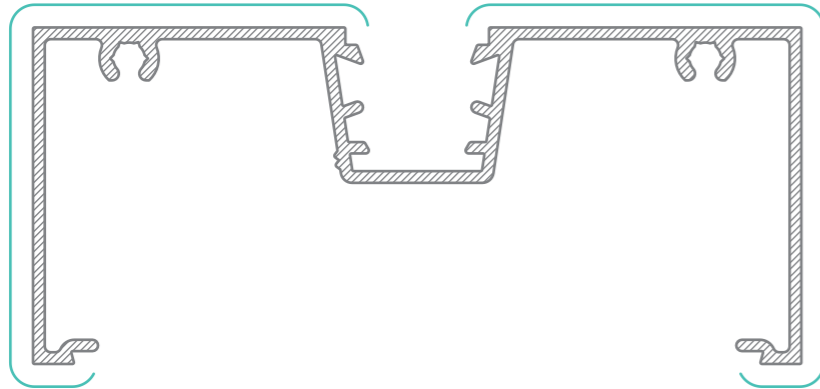

WASF 4008
Light Frame
AP = 548mm
PP = 183mm

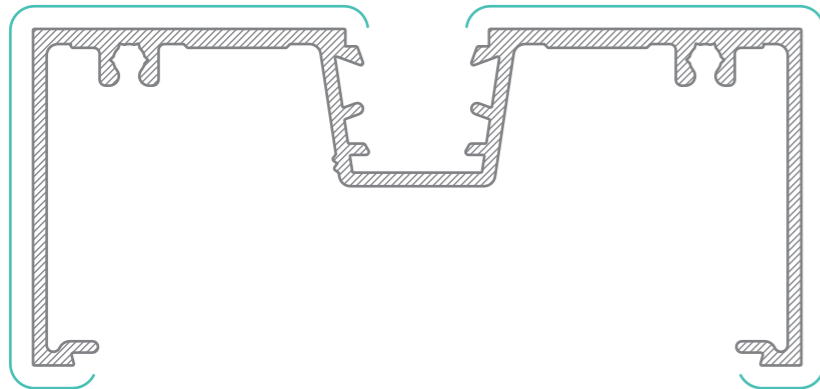

WASF 4000
Frame
AP = 546mm
PP = 186mm

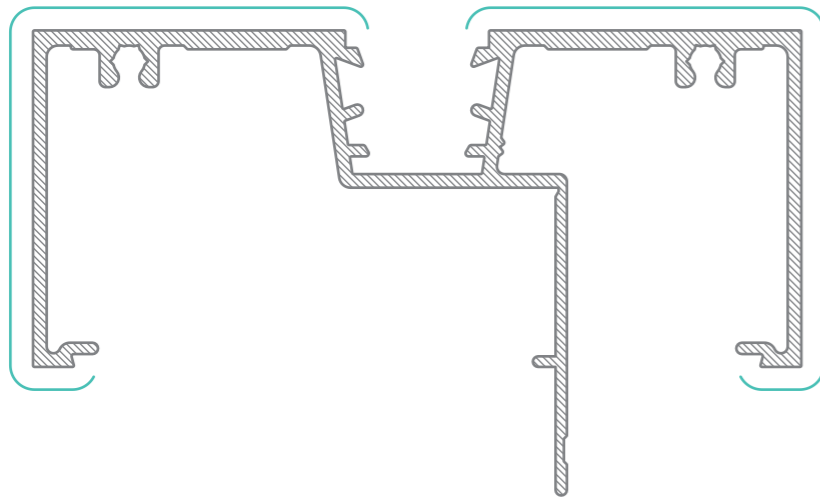

WASF 4018
Frame with Fin
AP = 652mm
PP = 183mm

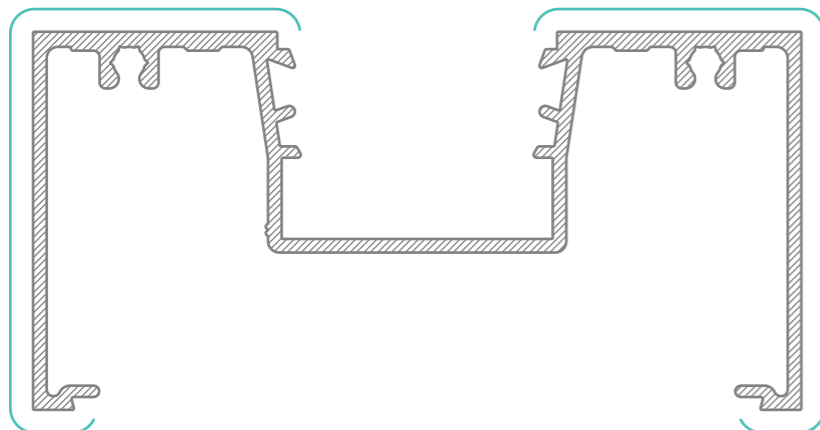

WASF 4200
DG Frame
AP = 604mm
PP = 176mm

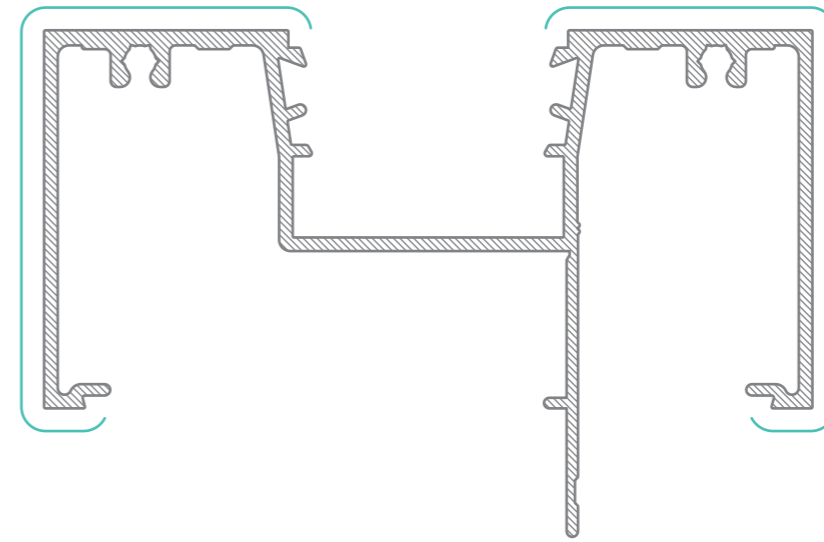

WASF 4218
Frame with Fin
AP = 686mm
PP = 176mm



WASF 4011
Plain Frame
AP = 448mm
PP = 202mm

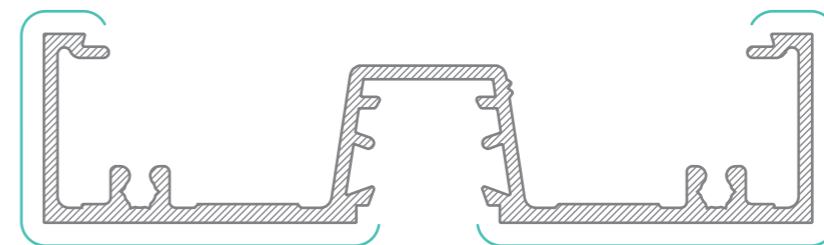

WASF 4029
25mm Centre Glaze Frame
AP = 468mm
PP = 144mm

SUBFRAME

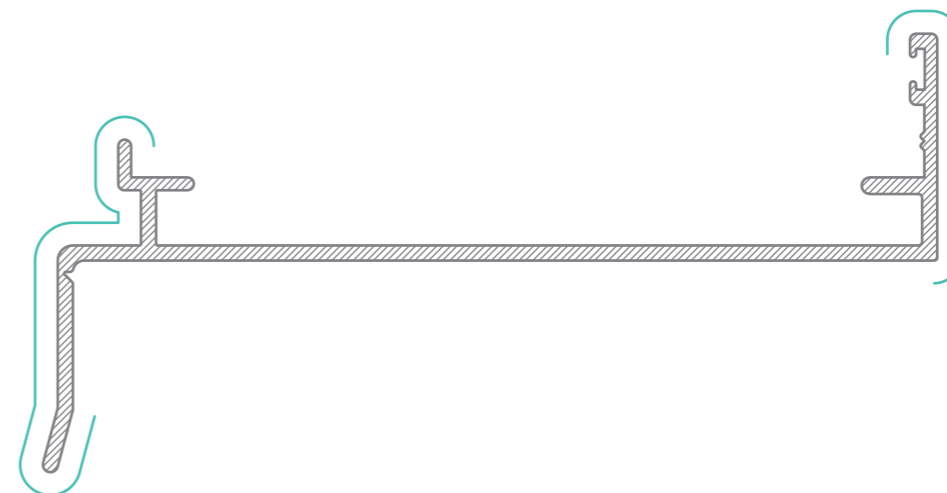

WASF 4014
114mm Subsill
AP = 416mm
PP = 128mm

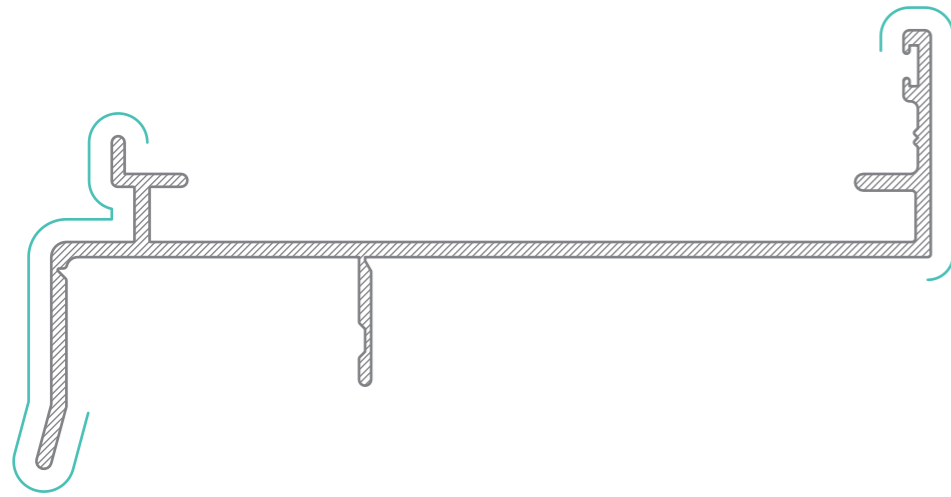

WASF 4024
Subsill with Fixing Fin
AP = 450mm
PP = 117mm

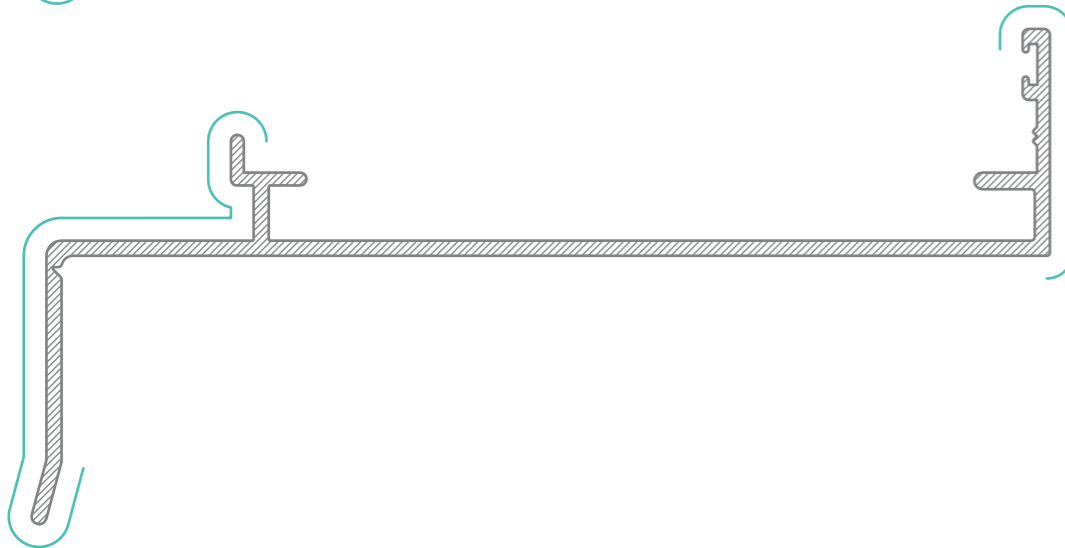

WASF 4015
131mm Subsill
AP = 464mm
PP = 159mm

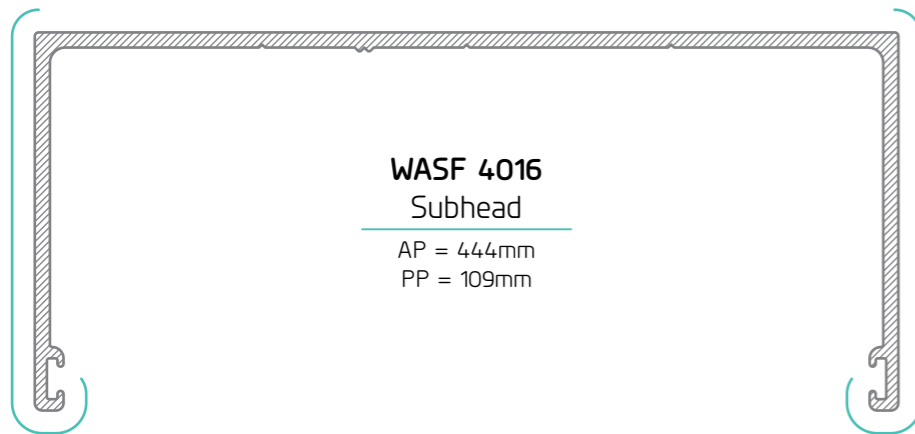

WASF 4016
Subhead
AP = 444mm
PP = 109mm

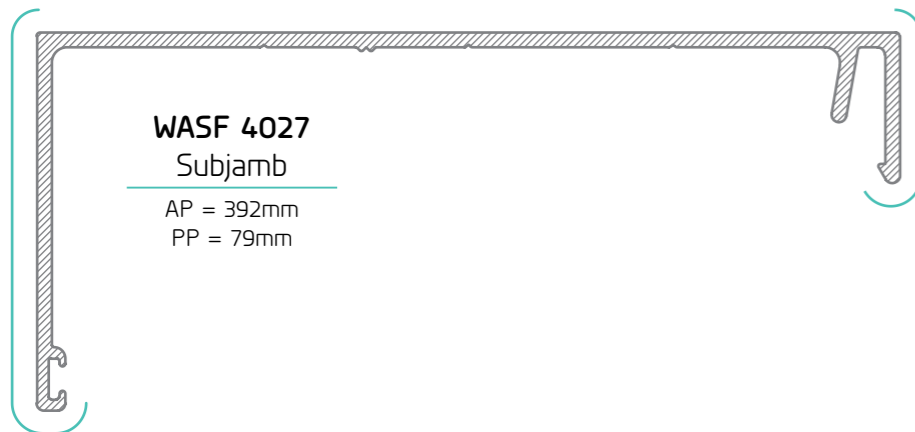

WASF 4027
Subjamb
AP = 392mm
PP = 79mm



WASF 4028
Sub Jamb Clip
AP = 115mm
PP = 39mm

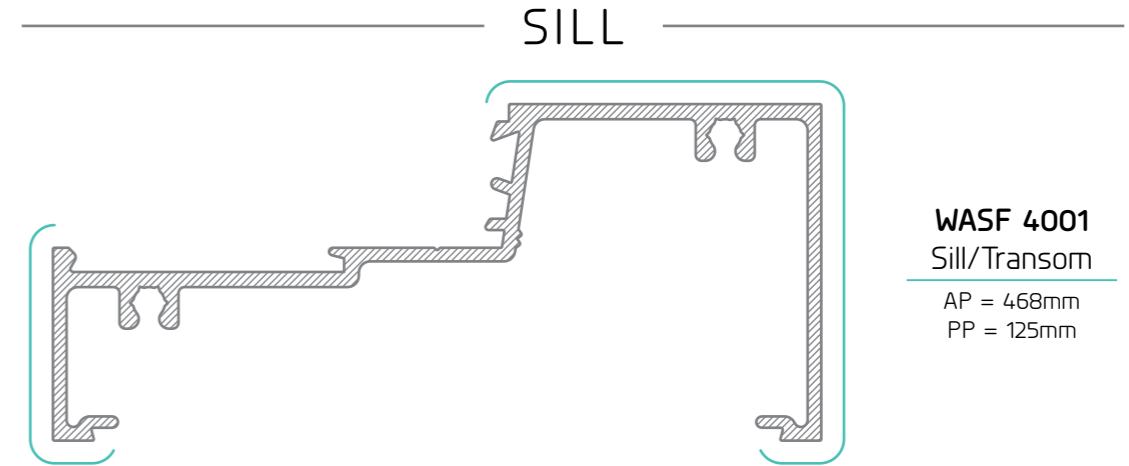

WASF 4001
Sill/Transom
AP = 468mm
PP = 125mm

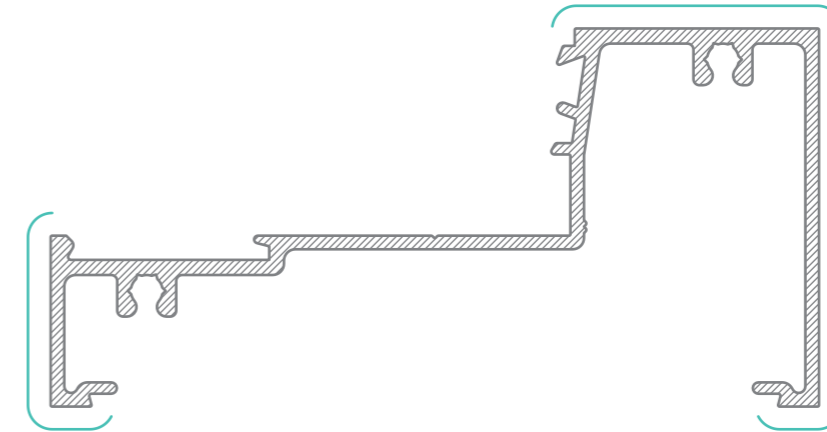

WASF 4201
DG Sill/Transom
AP = 491mm
PP = 120mm

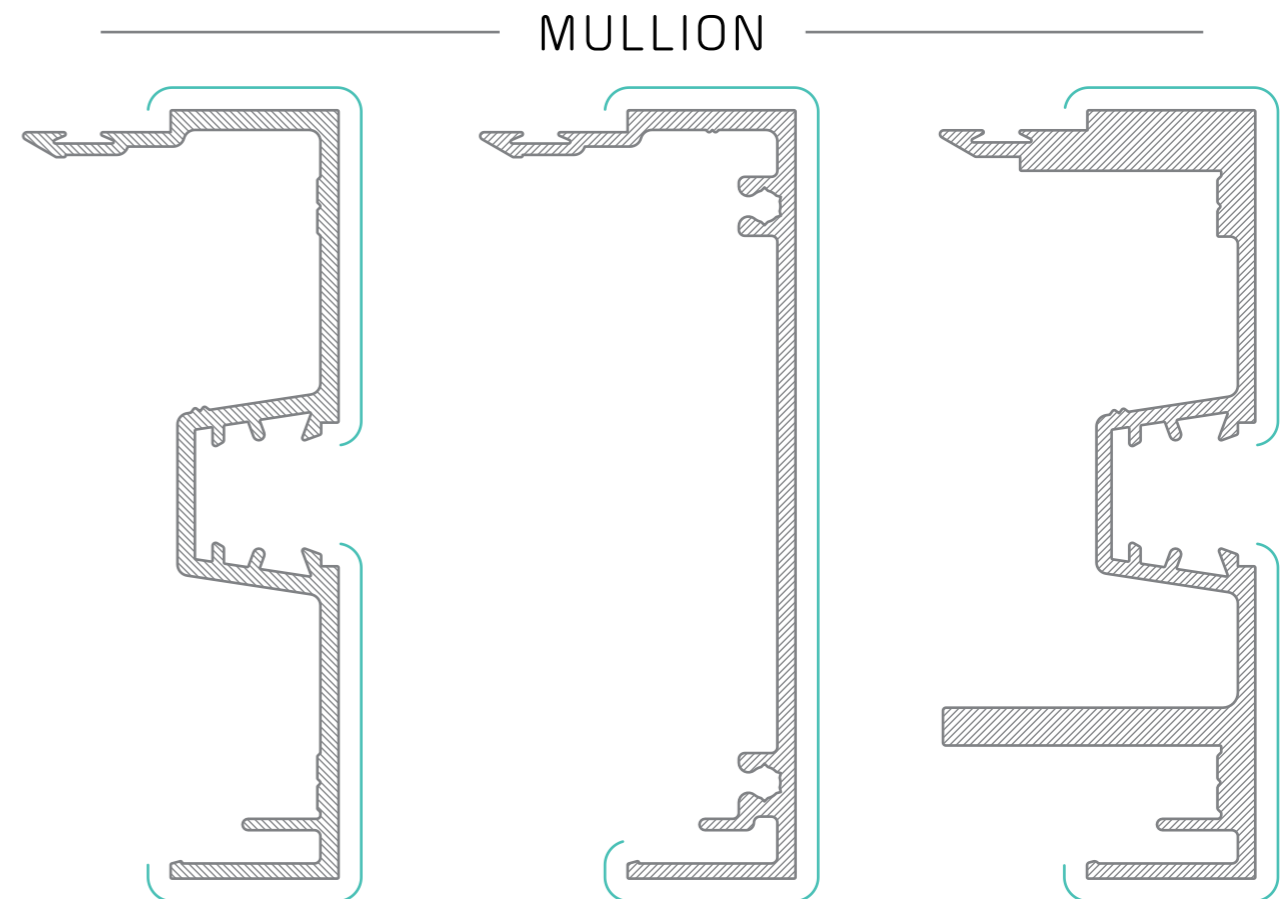

WASF 4006
Self Mating Mullion
AP = 456mm
PP = 128mm

WASF 4017
Flat Self Mating Mullion
AP = 390mm
PP = 148mm

WASF 4007
Heavy Self Mating Mullion
AP = 523mm
PP = 128mm

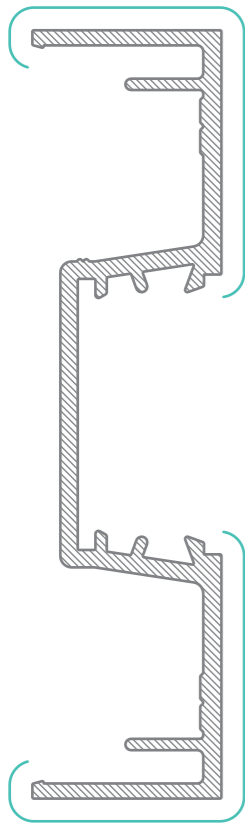

WASF 4207
DG Female Mullion
AP = 437mm
PP = 115mm

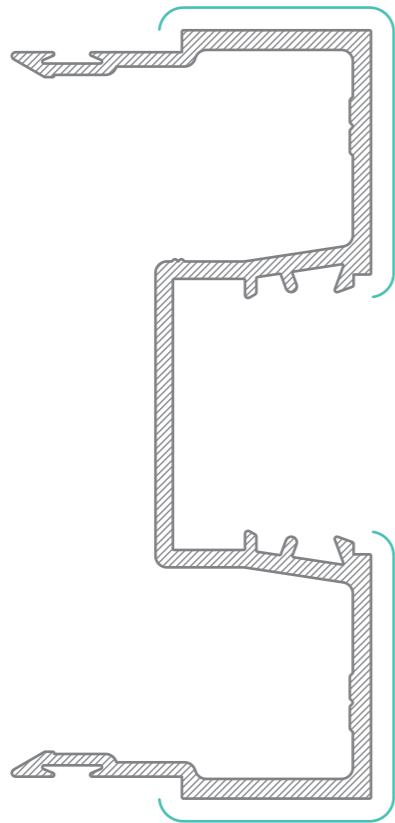

WASF 4206
DG Male Mullion
AP = 539mm
PP = 115mm

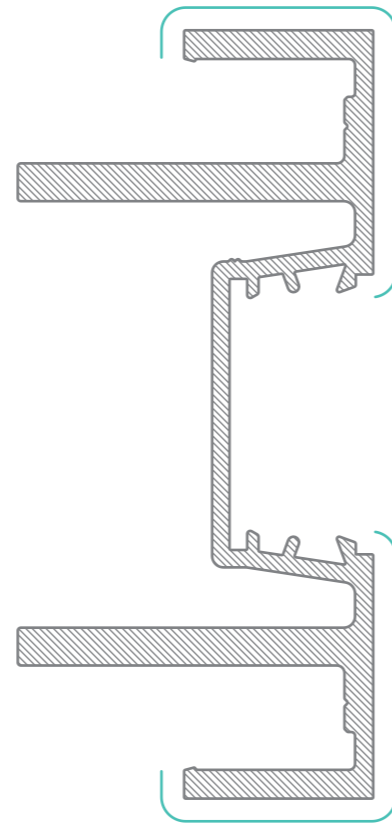

WASF 4209
DG Heavy Male Mullion
AP = 573mm
PP = 115mm

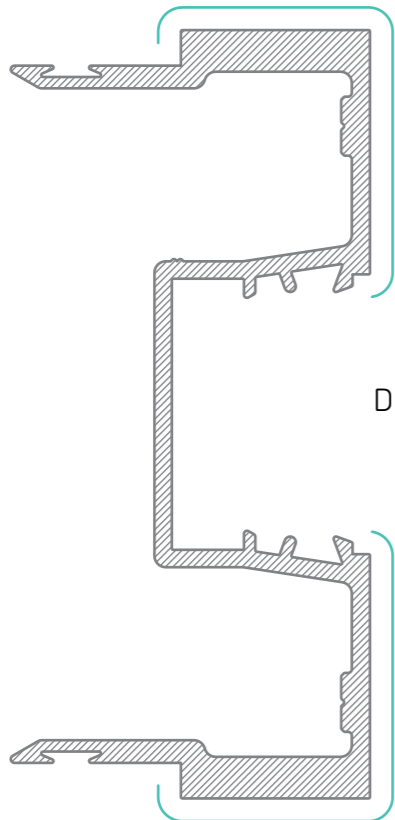

WASF 4208
DG Heavy Female Mullion
AP = 538mm
PP = 115mm

CONCEALED OVERHEAD CLOSER



WASF 4021
Concealed Overhead Closer Head
AP = 482mm
PP = 226mm



WASF 4022
Concealed Overhead Closer Infill
AP = 206mm
PP = 99mm

STILE

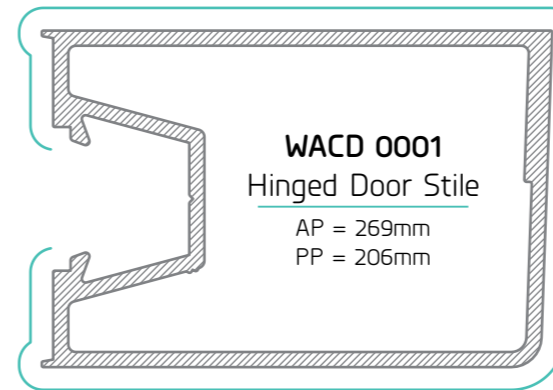

WACD 0001
Hinged Door Stile
AP = 269mm
PP = 206mm

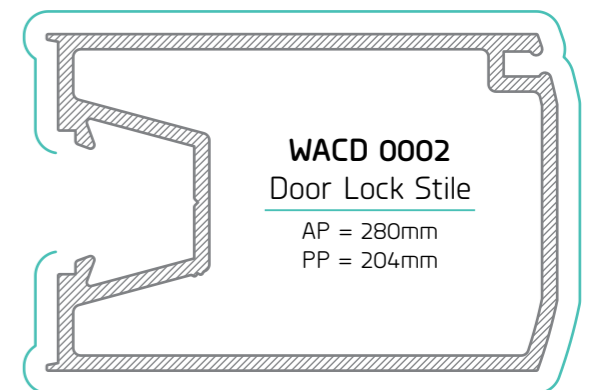

WACD 0002
Door Lock Stile
AP = 280mm
PP = 204mm

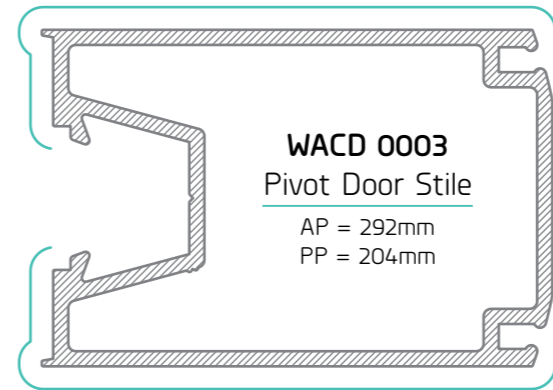

WACD 0003
Pivot Door Stile
AP = 292mm
PP = 204mm

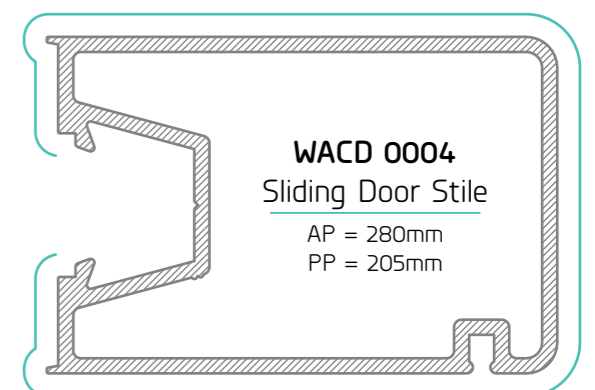

WACD 0004
Sliding Door Stile
AP = 280mm
PP = 205mm

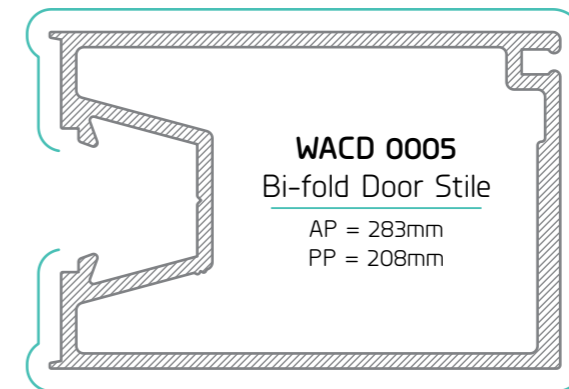

WACD 0005
Bi-fold Door Stile
AP = 283mm
PP = 208mm

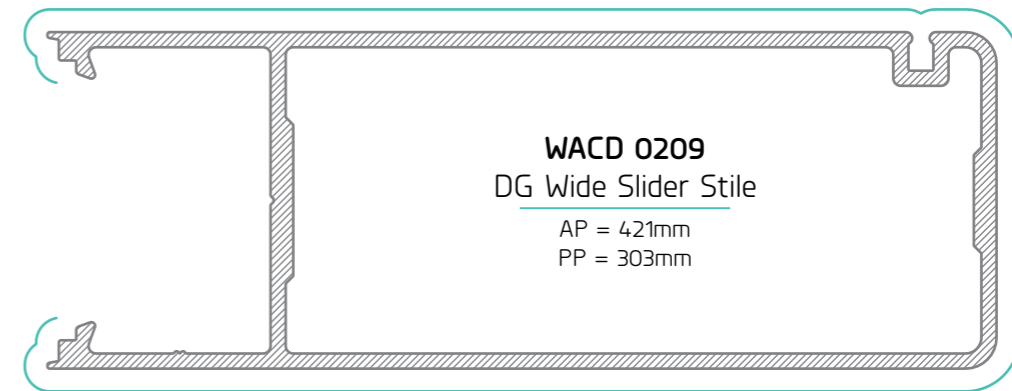
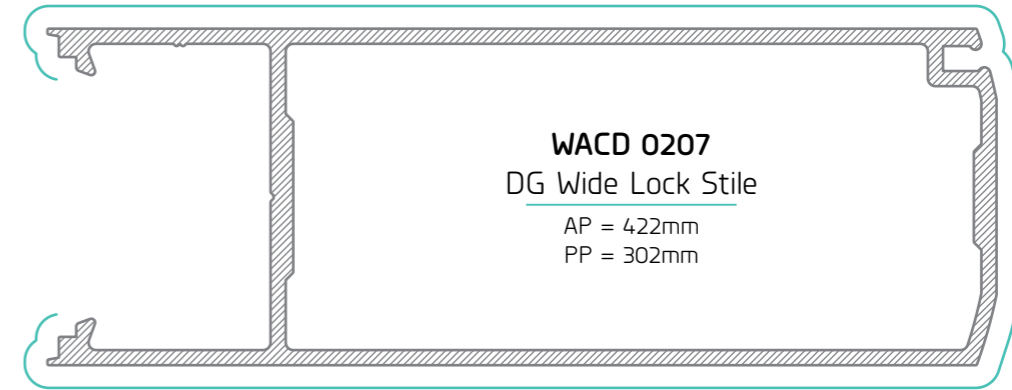
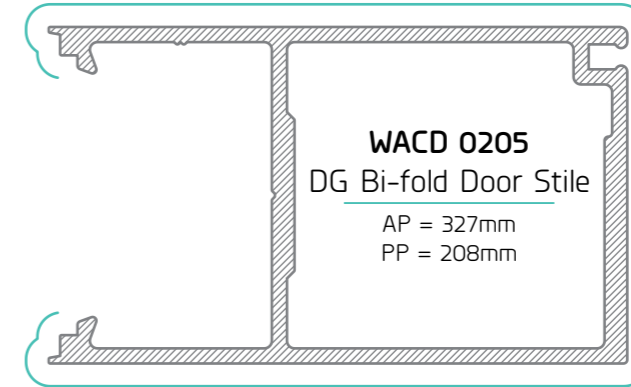
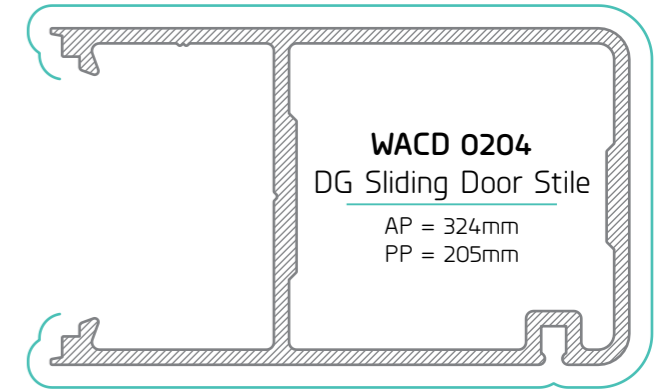
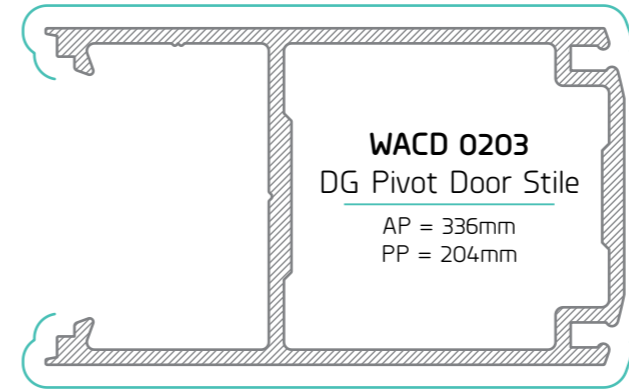
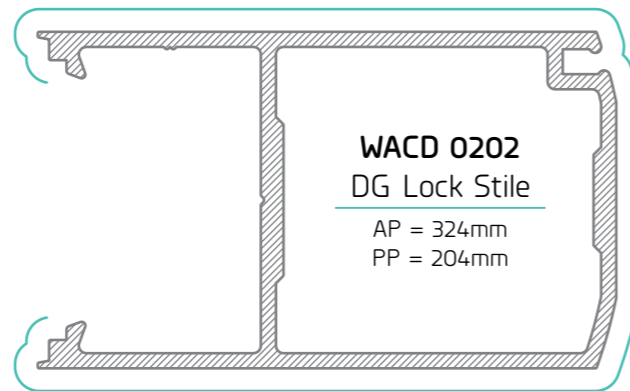
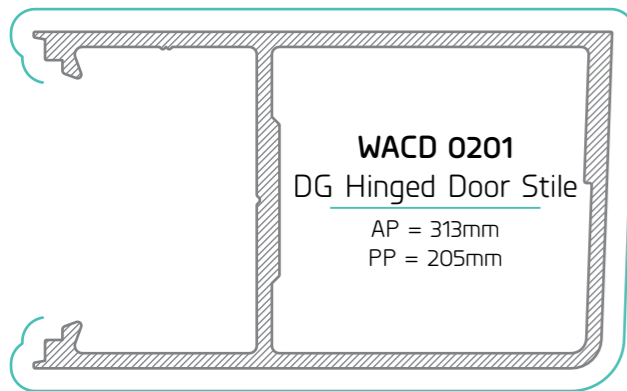
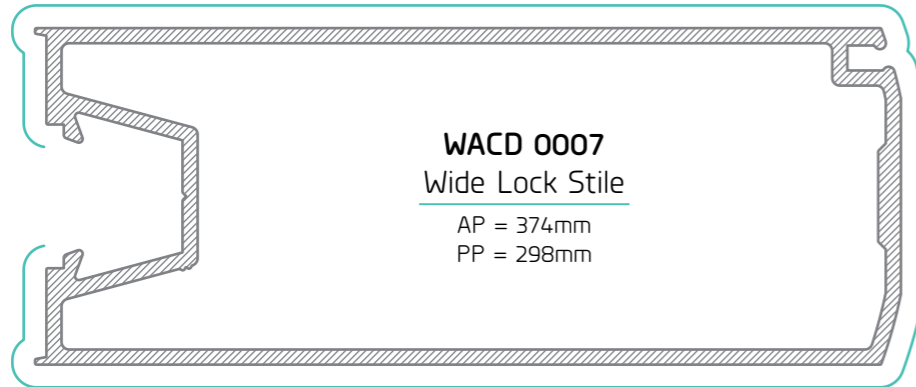

BEAD



WACD 0020
Door Bead

AP = 122mm
PP = 31mm



WACD 0220
DG Door Bead

AP = 79mm
PP = 22mm

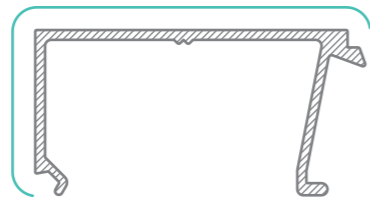

WASF 4002
Still/Transom Bead

AP = 182mm
PP = 63mm

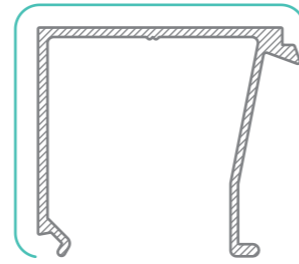

WASF 4202
DG Sill/Transom Bead

AP = 197mm
PP = 60mm

RAIL

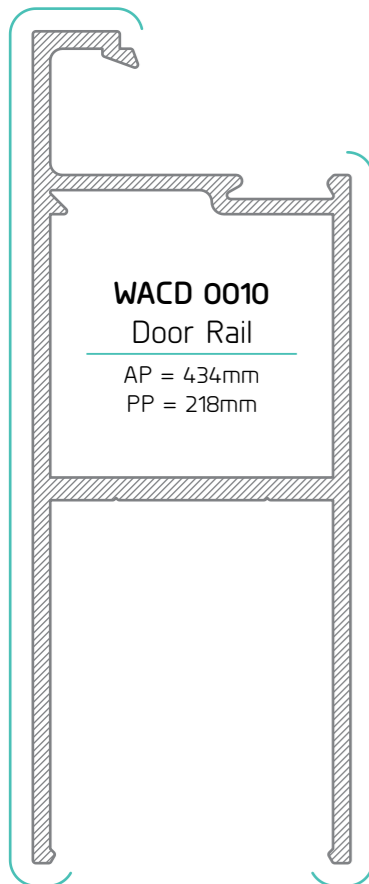

WACD 0010
Door Rail

AP = 434mm
PP = 218mm

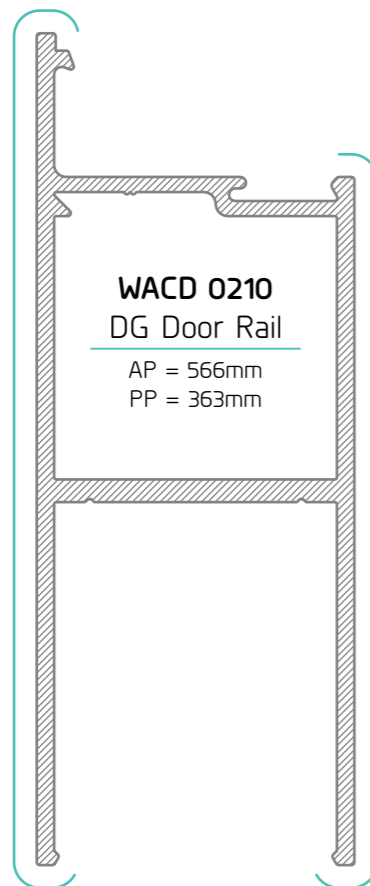

WACD 0210
DG Door Rail

AP = 566mm
PP = 363mm

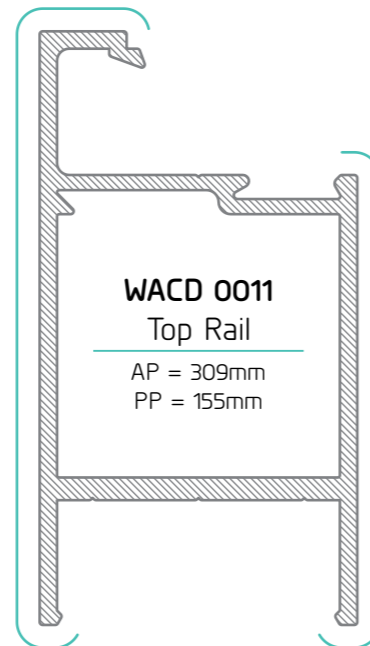

WACD 0011
Top Rail

AP = 309mm
PP = 155mm

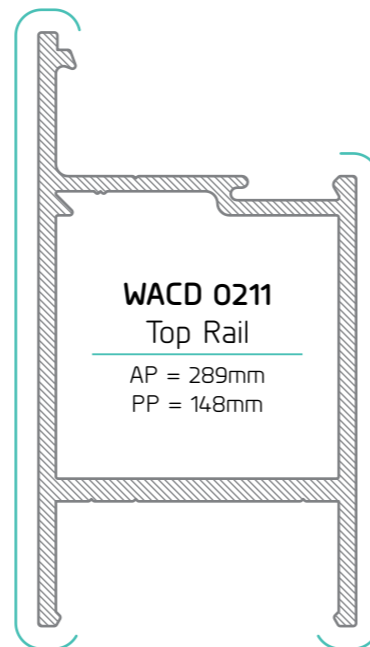

WACD 0211
Top Rail

AP = 289mm
PP = 148mm

MIDRAIL

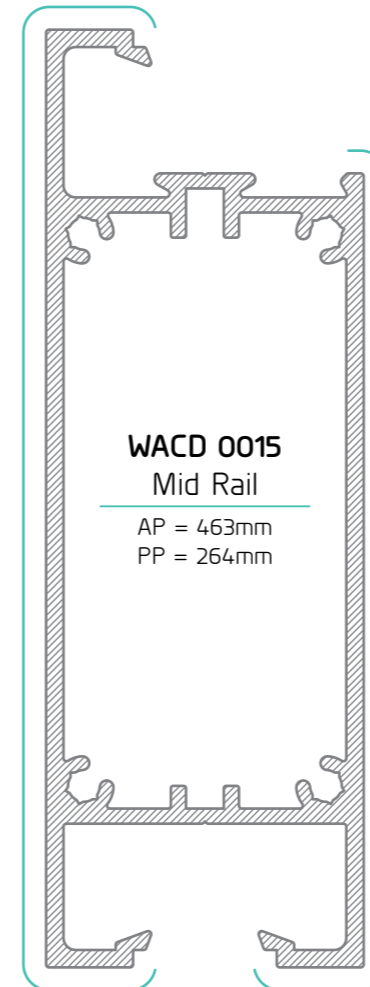

WACD 0015
Mid Rail

AP = 463mm
PP = 264mm

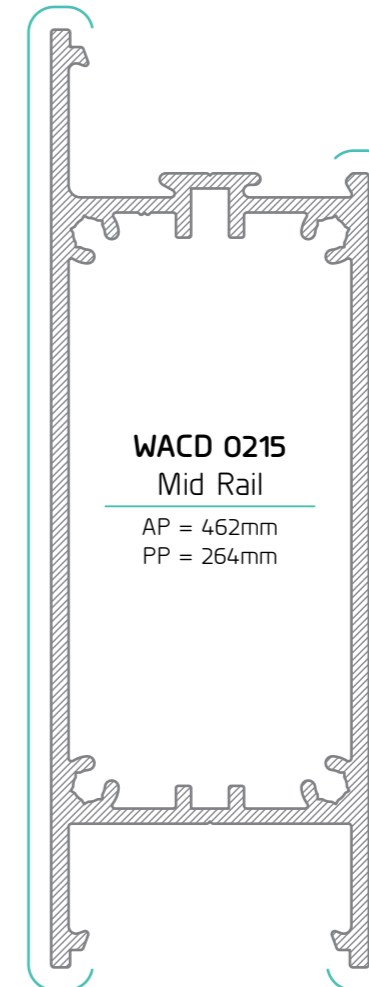

WACD 0215
Mid Rail

AP = 462mm
PP = 264mm

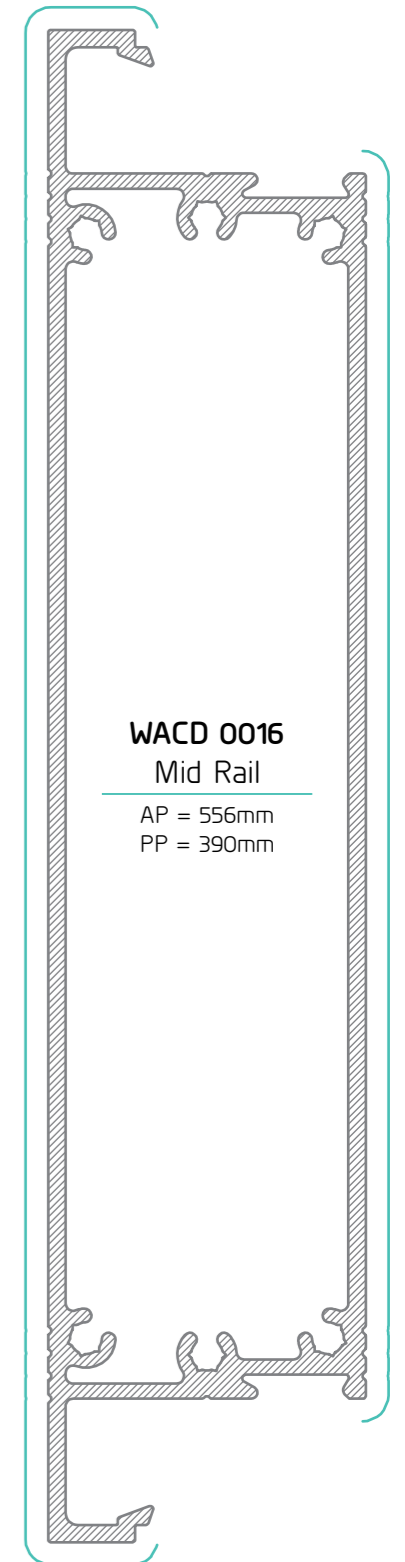

WACD 0016
Mid Rail

AP = 556mm
PP = 390mm

THRESHOLD

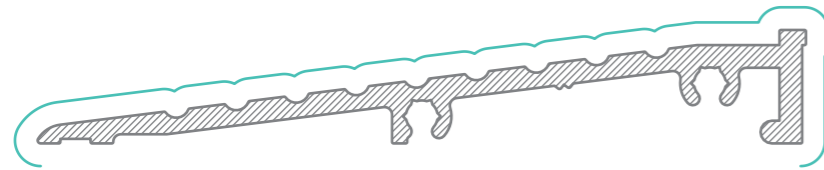

WASF 4013
Ramp Threshold
AP = 283mm
PP = 136mm

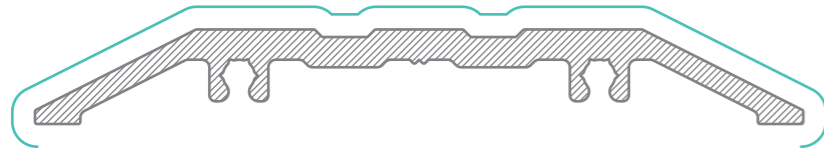

WASF 4023
Concealed Overhead Closer Threshold
AP = 263mm
PP = 113mm

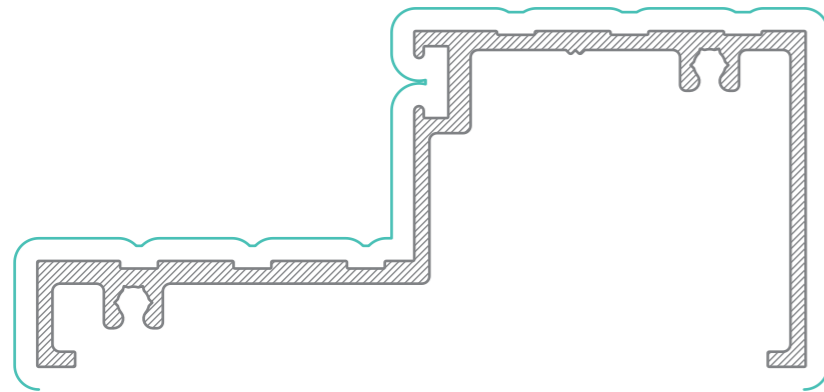

WASF 4025
Open Out Threshold
AP = 448mm
PP = 206mm

ADAPTORS

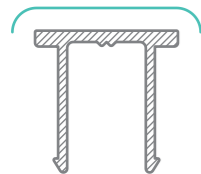

WASF 4005
Pocket Filler
AP = 110mm
PP = 20mm

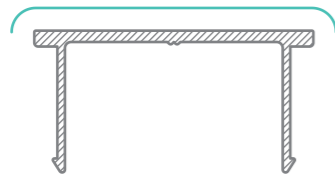

WASF 4205
DG Pocket Filler
AP = 146mm
PP = 38mm



WASF 4003
Glazing Adaptor
AP = 338mm
PP = 73mm



WASF 4203
DG Adaptor
AP = 330mm
PP = 55mm



WASF 4004
Flat Filler
AP = 210mm
PP = 92mm



WASF 4019
Flat Filler with Screw Flutes
AP = 230mm
PP = 101mm

GLAZING ADAPTORS

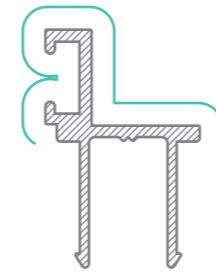

WASF 4009
35mm Door Stop
AP = 152mm
PP = 44mm

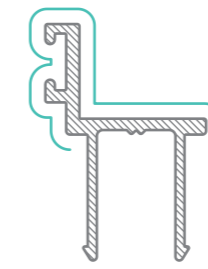

WASF 4026
35mm Door Stop with Mohair
AP = 148mm
PP = 60mm



WASF 4010
45mm Door Stop
AP = 149mm
PP = 46mm

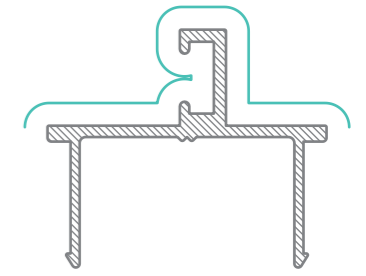

WASF 4211
45mm Door Stop
AP = 185mm
PP = 77mm



WACD 0008
Hinge Door Stop
AP = 100mm
PP = 65mm

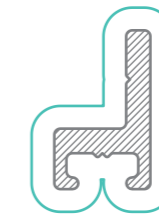

WASF 4020
Door Stop
AP = 80mm
PP = 44mm

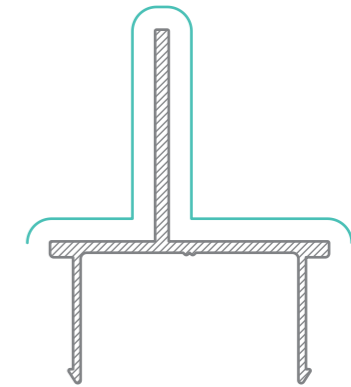

WASF 4210
DG Sash Adaptor
AP = 202mm
PP = 93mm

CORNER POST

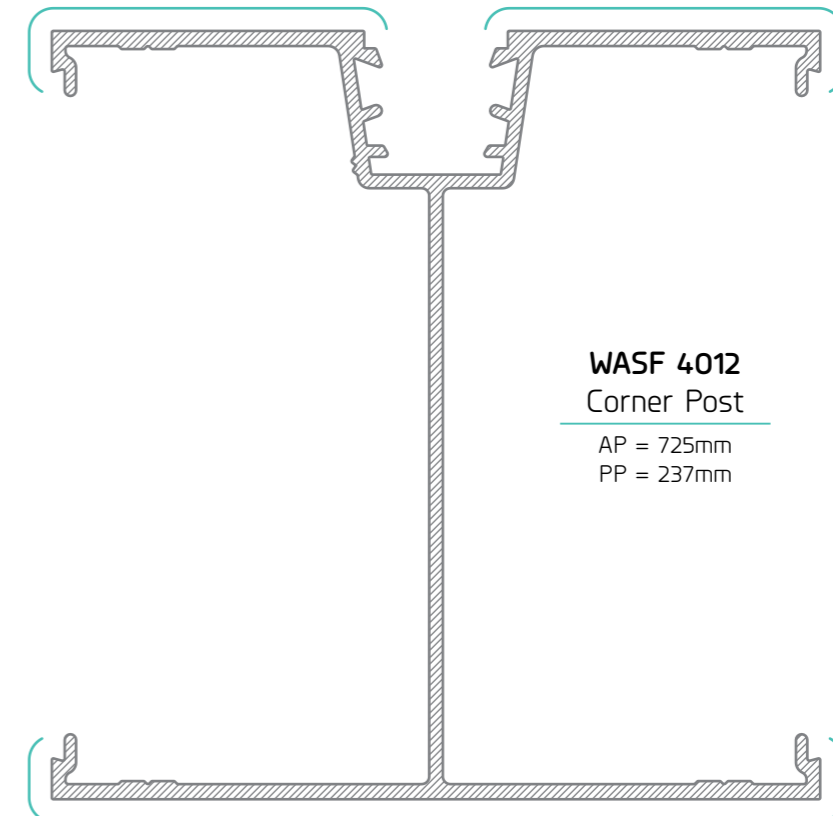

WASF 4012
Corner Post
AP = 725mm
PP = 237mm

COUPLER

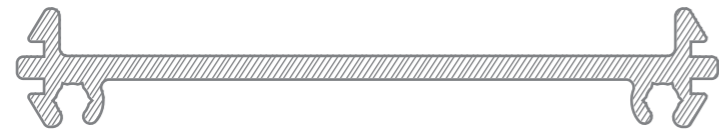

WACS007
Commercial Glaze Coupler
AP = 260mm
PP = 0mm

MISCELLANEOUS

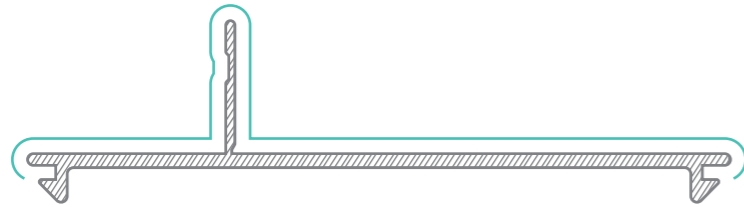

WAWF012
Snap-In Reveal Fin
AP = 239mm
PP = 126mm

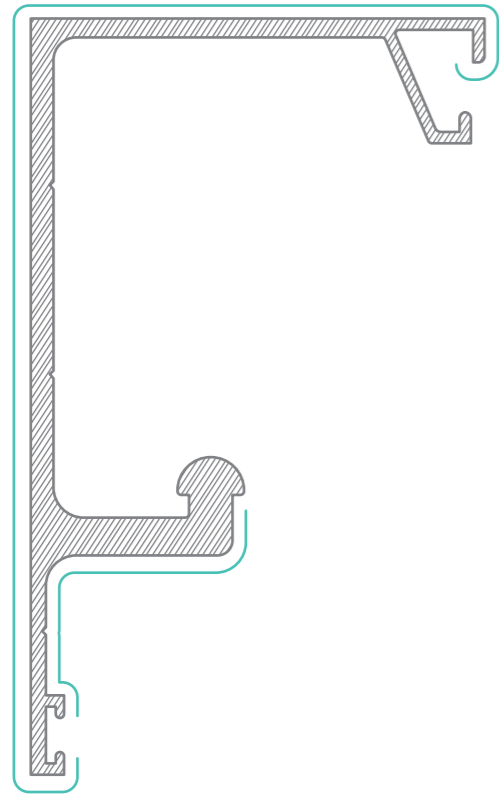

20-PA50TT
overhead track
AP = 447mm
PP = 226mm

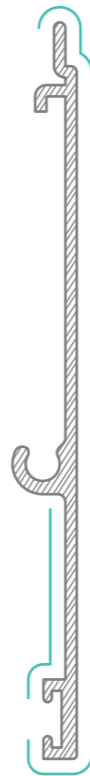

20-PA50PT
pelmet
AP = 245mm
PP = 140mm

HEAD

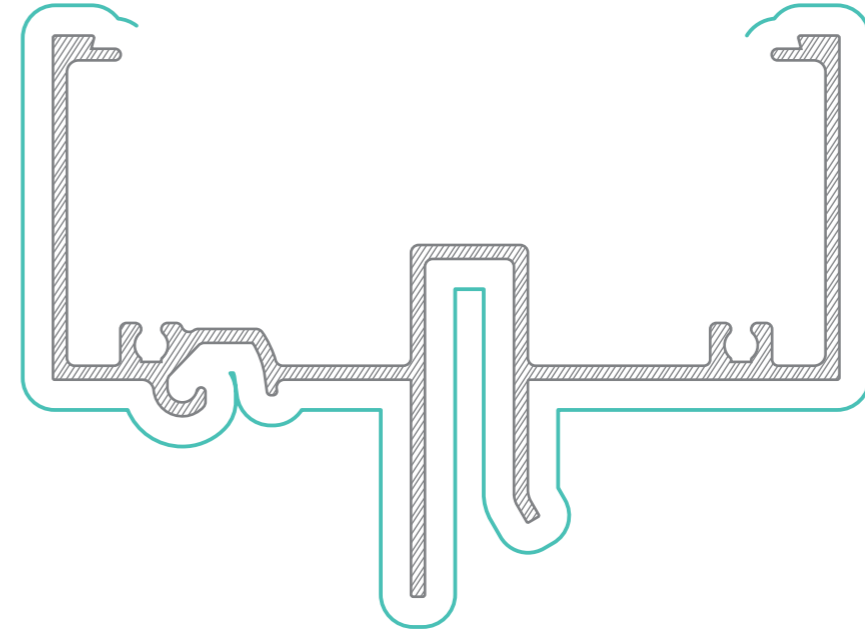

WAAW100
Awning Head
AP = 618mm
PP = 361mm

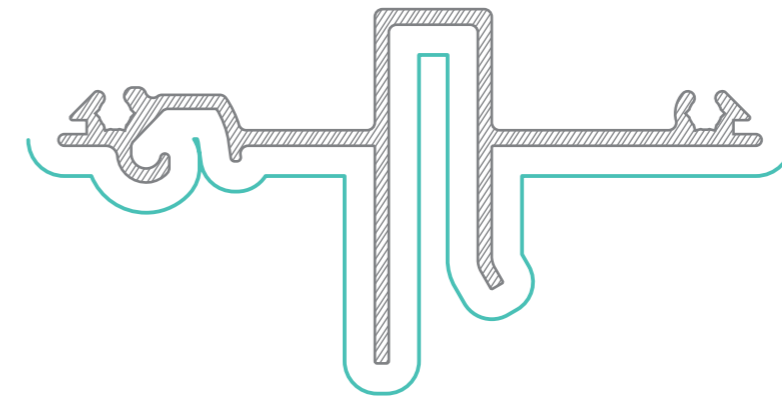

WAAW103
Awning Head Clip-In
AP = 406mm
PP = 420mm

SILL

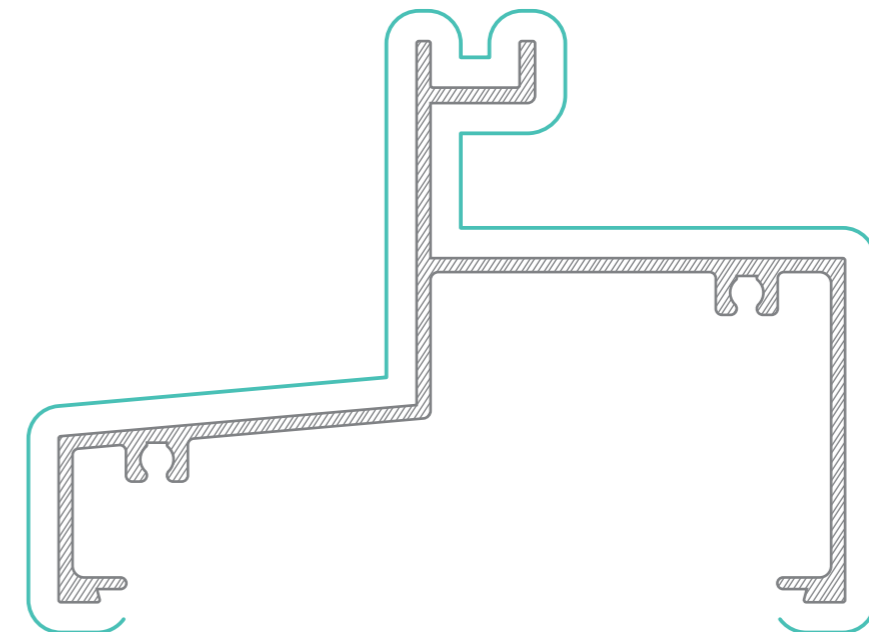

WAAW101
Awning Sill
AP = 526mm
PP = 302mm

SASH

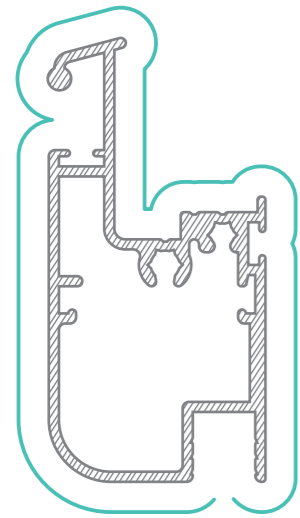

WAAW124
Awning Top Rail
AP = 234mm
PP = 196mm

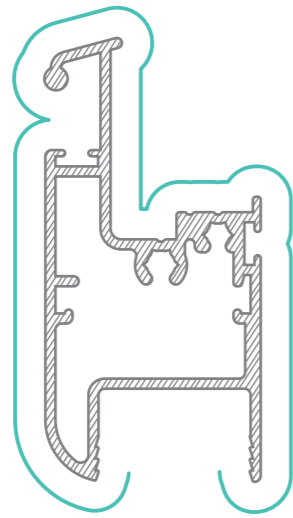

WAAW153
Awning DG Top Rail
AP = 240mm
PP = 184mm

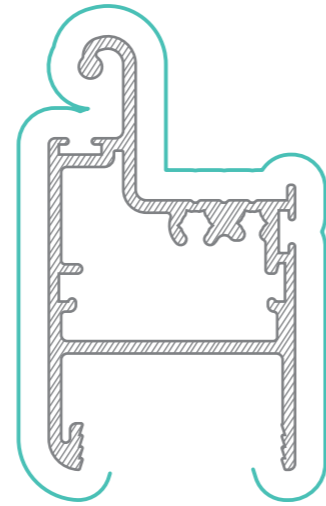

WAAW161
Awning DG Top Rail
AP = 248mm
PP = 185mm

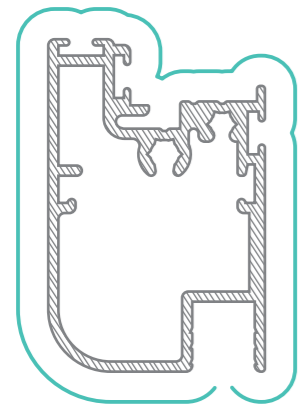

WAAW125
Awning Sash Stile/Rail
AP = 200mm
PP = 175mm

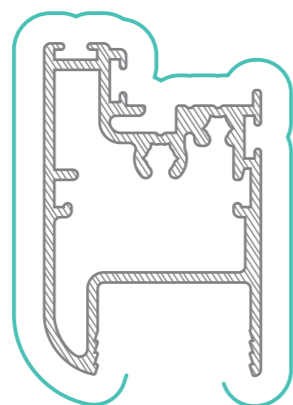

WAAW154
Awning DG Stile/Rail
AP = 205mm
PP = 162mm

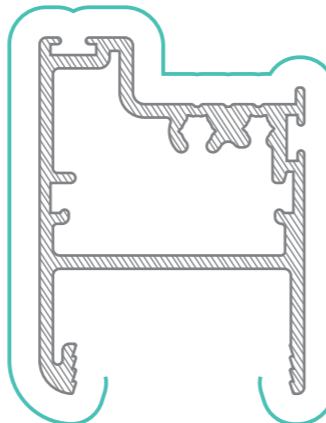



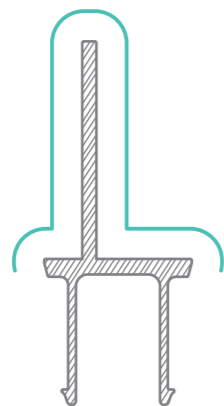

WAAW162
Awning DG Stile/Rail
AP = 207mm
PP = 144mm

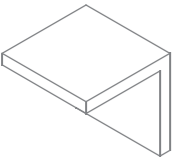
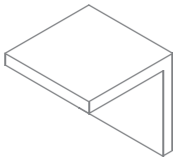
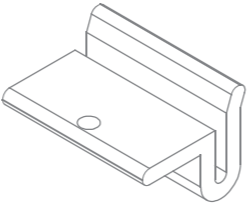

WAAW102
Sash Stop
AP = 162mm
PP = 79.5mm

GLASS THICKNESS	ROLL-IN WEDGE	CAPTIVE WEDGE	ROLL-IN WEDGE BOTH SIDES
5mm GLASS	 WINSFR-B (BLUE)	 WINSFC-Y (YELLOW)	 WINSFR-B (BLUE)
6mm and 6.38mm GLASS	 WINSFR-Y (YELLOW)	 WINSFC-Y (YELLOW)	 WINSFR-Y (YELLOW)
8mm and 8.38mm GLASS	 WINSFR-W (WHITE)	 WINSFC-R (RED)	 WINSFR-G (GREEN)
10mm and 10.38mm GLASS	 WINSFR-R (RED)	 WINSFC-R (RED)	 WINSFR-R (RED)
24mm GLASS	 WINSFR-Y (YELLOW)	 WINSFC-Y (YELLOW)	 WINSFR-Y (YELLOW)
28mm GLASS	 WINSFR-R (RED)	 WINSFC-R (RED)	 WINSFR-R (RED)
MISCELLANEOUS			
 WINSF-DS DOOR STOP	 WINSMS SPLIT MULLION SEAL	 WINSF-SS SUBSILL SEAL	 WINSFB511S BRUSH SEAL
	 SAW002 Q'LON SEAL	 SAW007 FIN SEAL	 WIN WC CHANNEL
 WINSF-SH SUBHEAD SEAL	 W**WCDG GLAZING CHANNEL [channel to suit 10-16mm glass]	 WIN**DG GLAZING CHANNEL [channel to suit 18-22mm glass]	

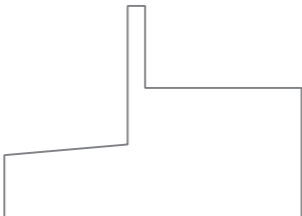
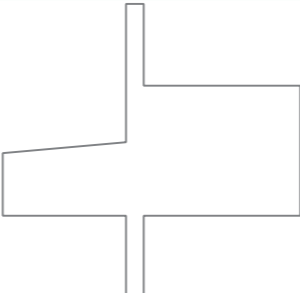
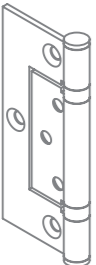
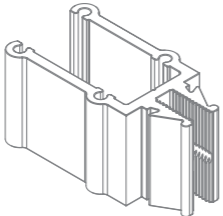
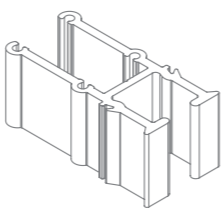
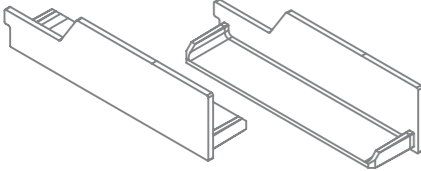
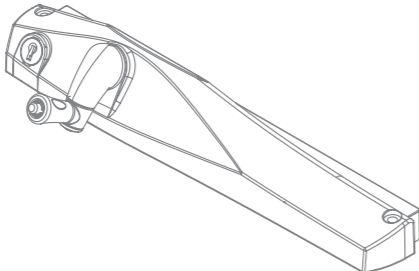
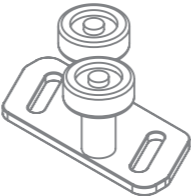
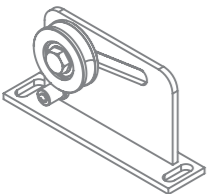
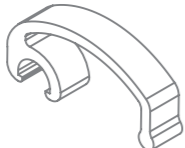
NOTE: ** is replaced with glass size [i.e. W10WCDG - 10mm glass]

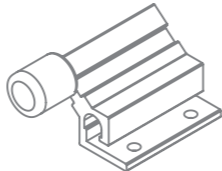
<p>SAW001M corner stake</p>	<p>SAW006M 22mm sash corner stake</p>	<p>SAW016 22mm sash retainer clip</p>	
			
<p>SAW011 head gasket</p>	<p>SAW012 sill gasket</p>	<p>SAW013 transom gasket</p>	
			
<p>SFD068 fast fix s/steel hinge</p>	<p>SPIGOTHDKITS single glazed spigot kit</p>	<p>SPIGOTHDKITG double glazed spigot kit</p>	
			
<p>WINSF001 subsill end caps black [pair]</p>	<p>CHAIN WINDER to suit 40kg & 60kg sash</p>	<p>20-PA50100GU twin wheel bottom guide</p>	
			
<p>20-PA50100WA roller assembly - 200kg max</p>	<p>20-PA50LLP polymer extrusion joiner</p>	<p>20-PA50EC polymer end cap</p>	<p>20-22-PA50100 overhead track door stop</p>
			

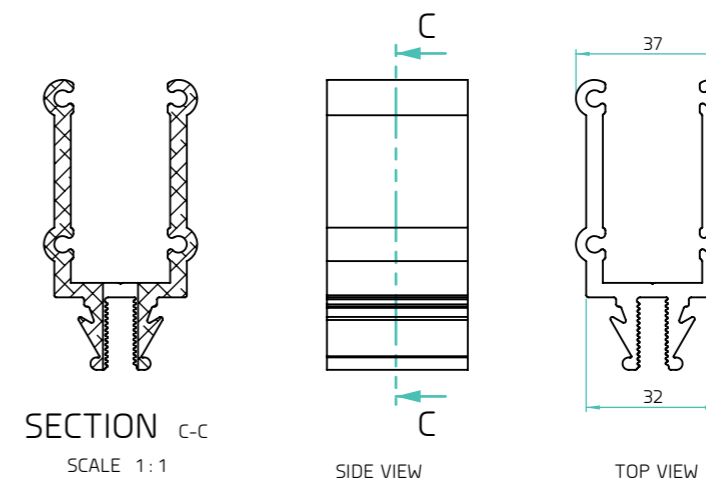
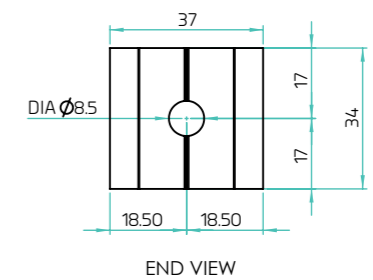
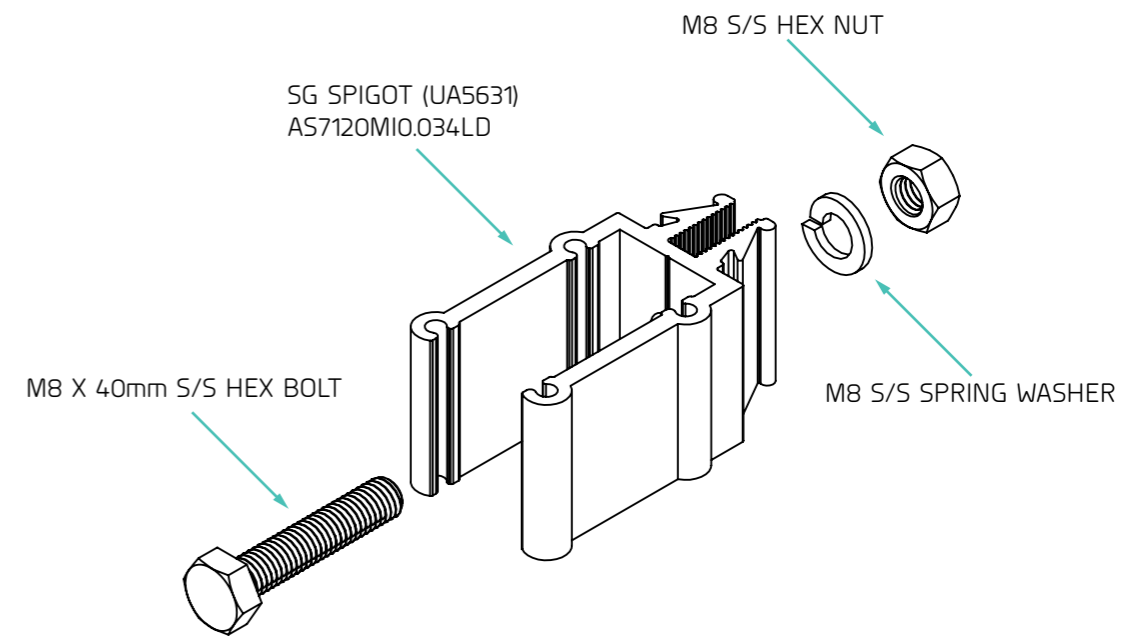

NOTE: 8.5mm diameter hole drilled through centre

SPIGOTHDKITS

- PACK CONTAINS:
- 4 - SG SPIGOTS
 - 4 - M8 40mm S/S HEX BOLTS
 - 4 - M8 S/S SPRING WASHERS
 - 4 - M8 S/S HEX NUTS

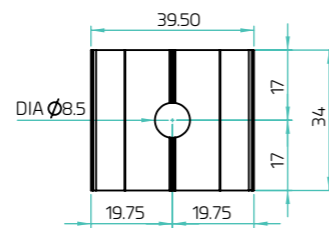
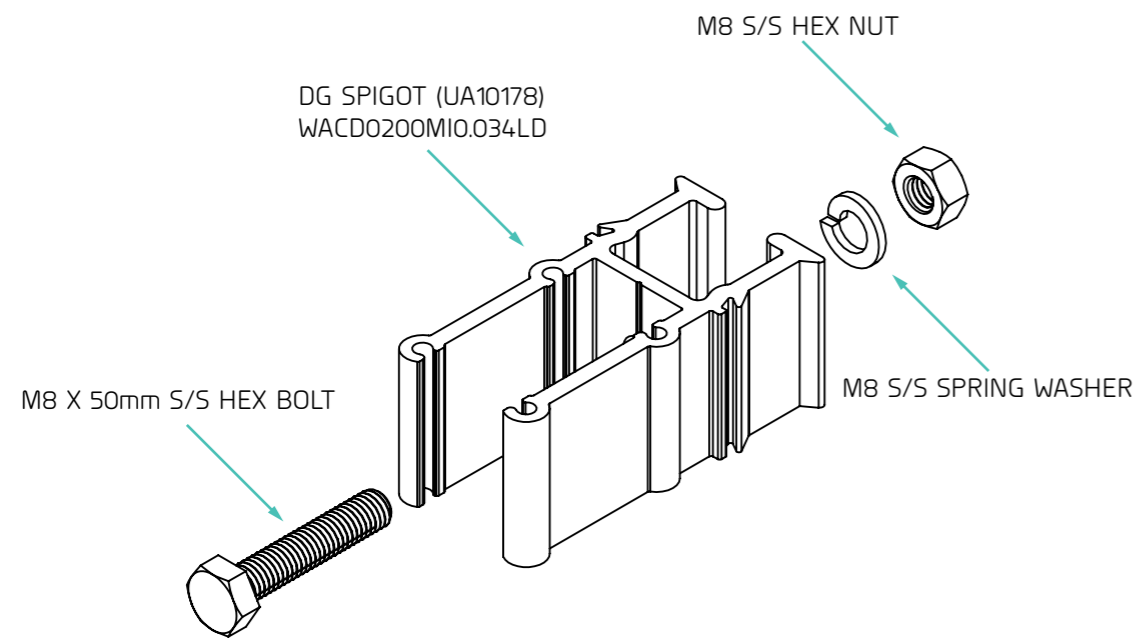

END VIEW

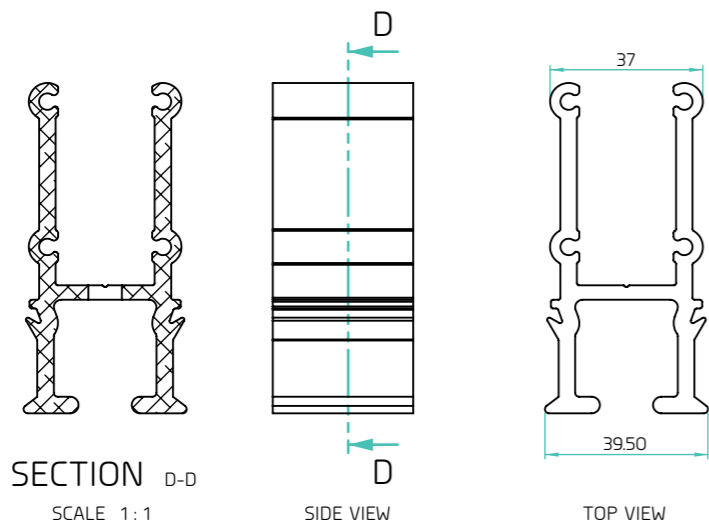

NOTE: 8.5mm diameter hole drilled through centre

SPIGOTDKITD

- PACK CONTAINS:
 4 - DG SPIGOTS
 4 - M8 X 50mm S/S HEX BOLTS
 4 - M8 S/S SPRING WASHERS
 4 - M8 S/S HEX NUTS

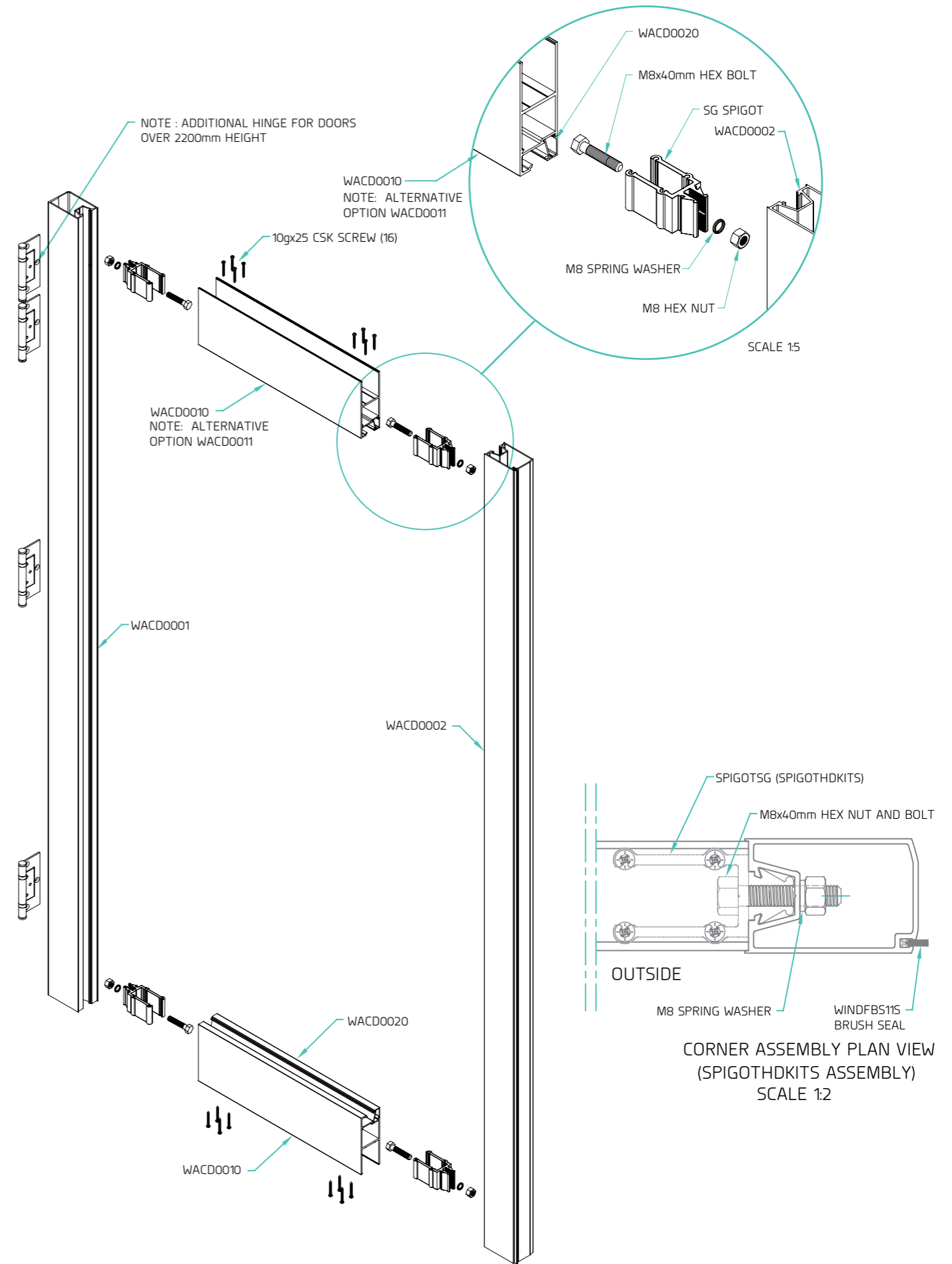

The Sub Sill End Cap is a purpose designed component reducing labour time required for the installation and sealing the 101.60mm commercial Sub Sill without the need of additional trim angles.

The Sub Sill End Caps are available as a set with [1 left and 1 right end].

Step 1.

Starting from the end of the sub sill, run a full bead of silicone sealant around the edges of the sub sill. Run a close zig zag pattern bead across the bottom face of the sub sill 20mm in from the end. Apply sealant to edges of the sub sill as shown in detail below.

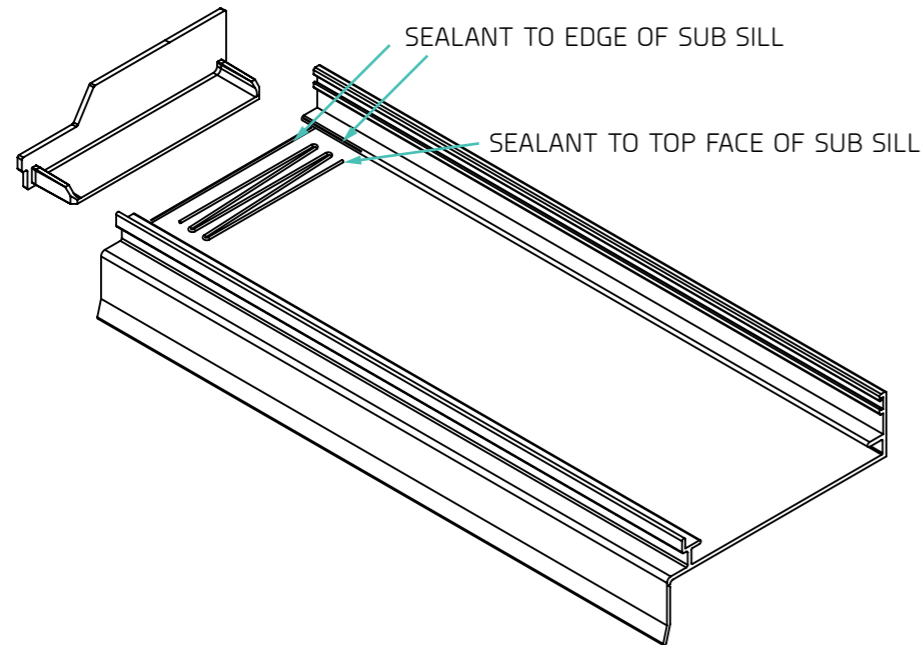

Step 2.

Insert the sub sill end cap into the sub sill and push home. Ensure the sealant has completely sealed off the end of the sub sill. Wipe away any excess sealant making sure that the top face of the end cap and the sill support legs are free of sealant build up.

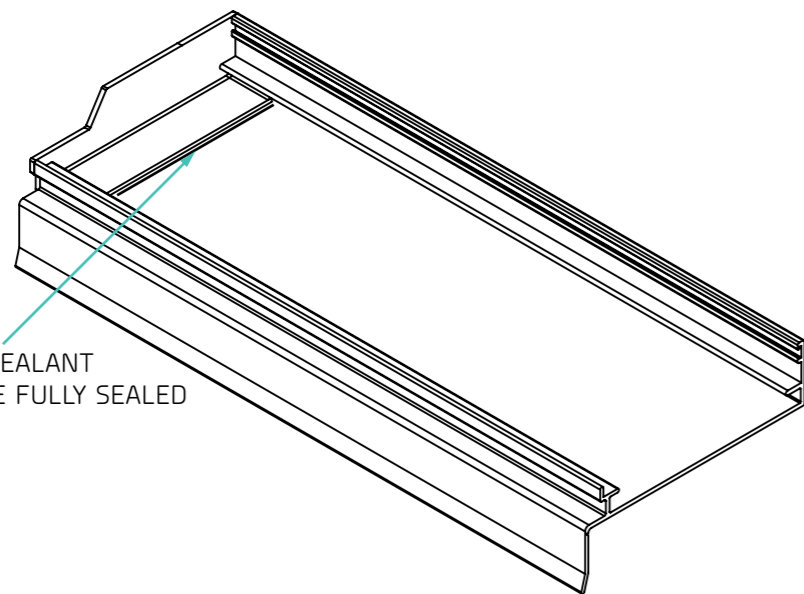

NOTE:
To ensure maximum waterproofing, use Polyurethane Sealant on Powder Coated Aluminium finishes, and applying Silicon Sealant on Anodised Aluminium finishes.

OUTSIDE

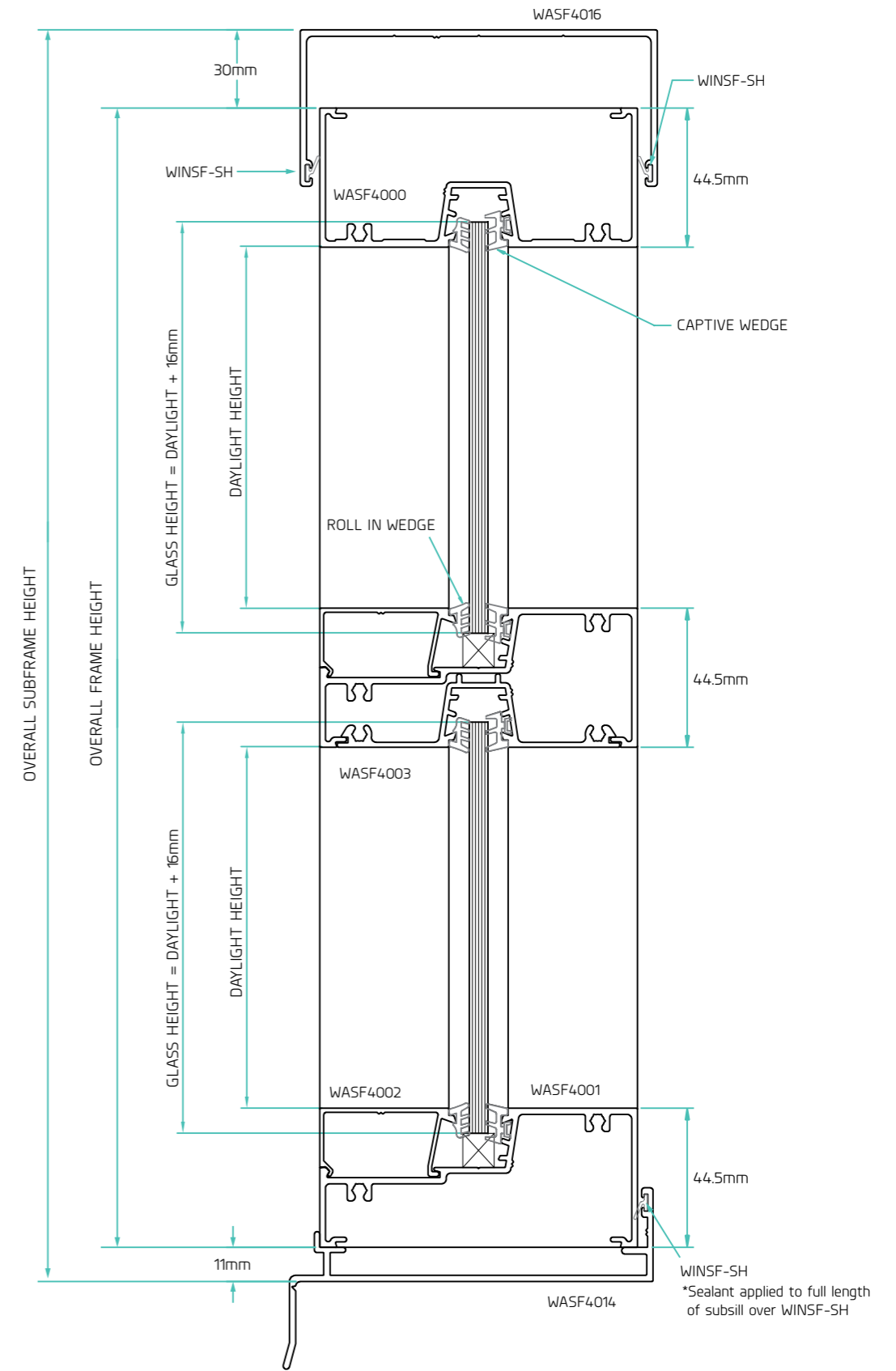

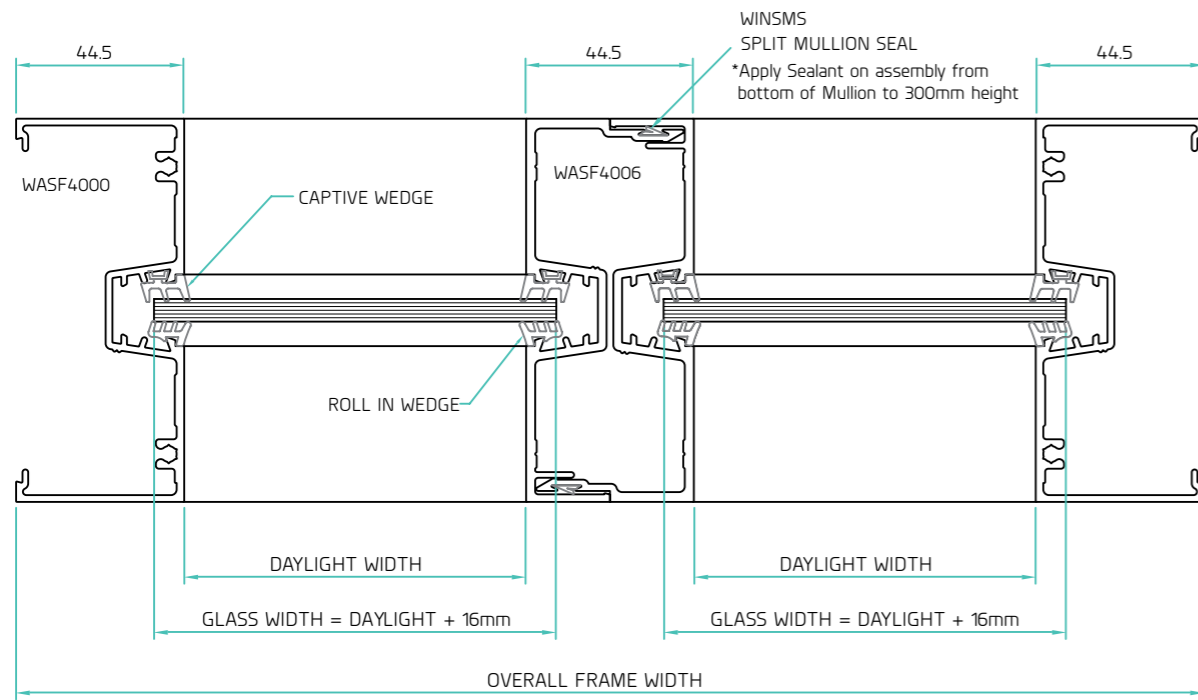

OUTSIDE

ALTERNATIVE MULLIONS

WASF4006/4007

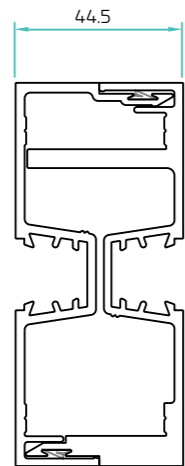

WASF4007/4007

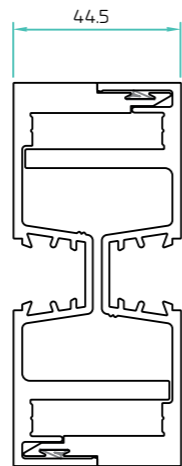

OUTSIDE

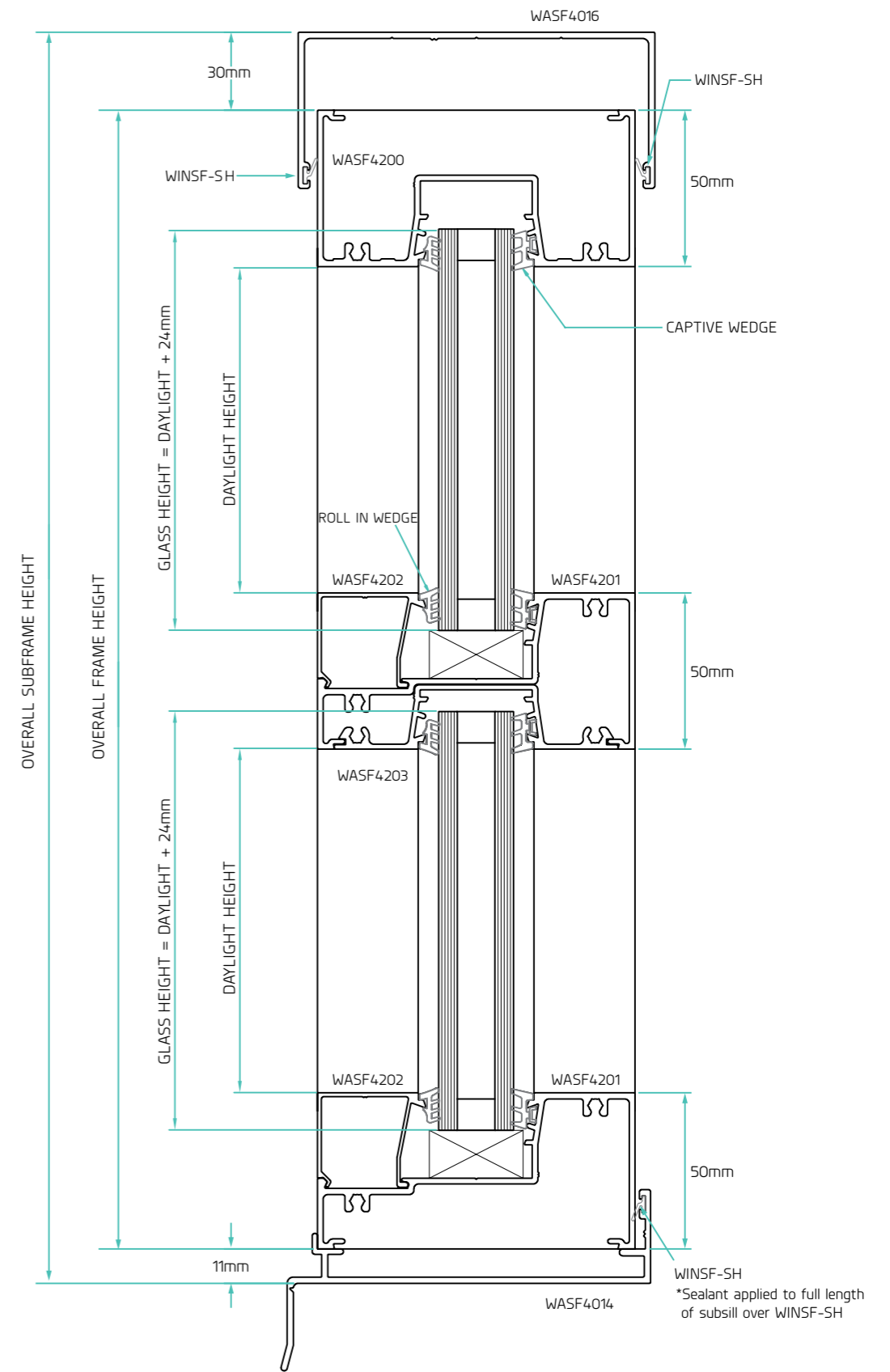

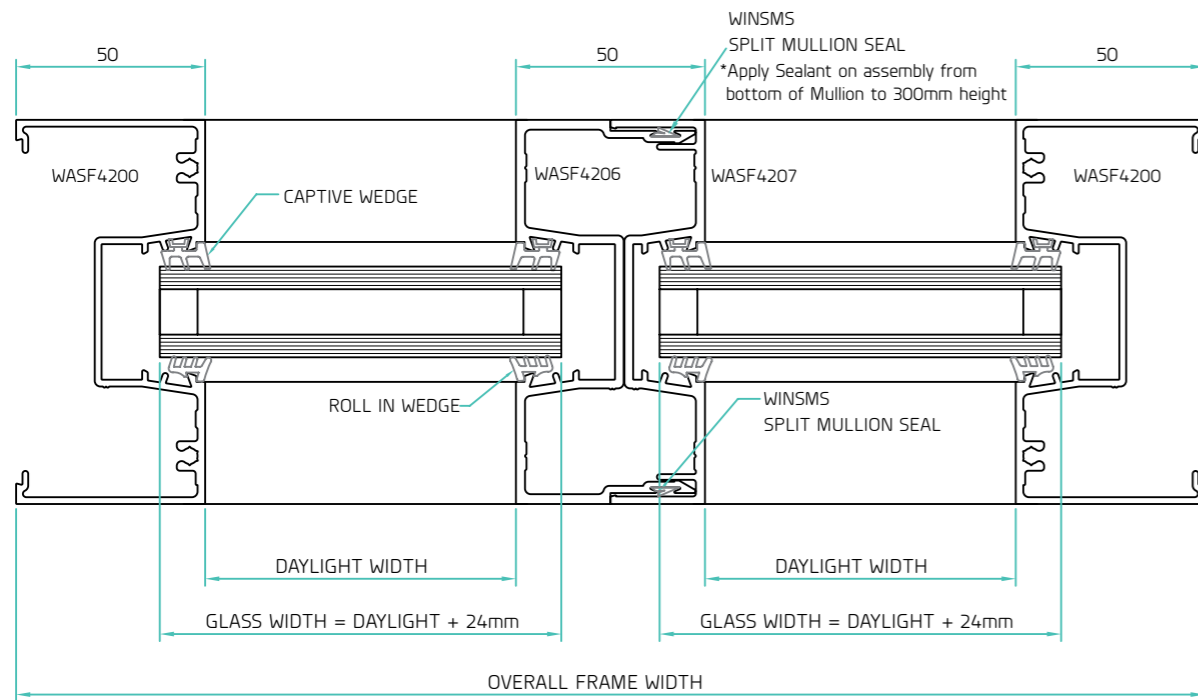

OUTSIDE

ALTERNATIVE MULLIONS

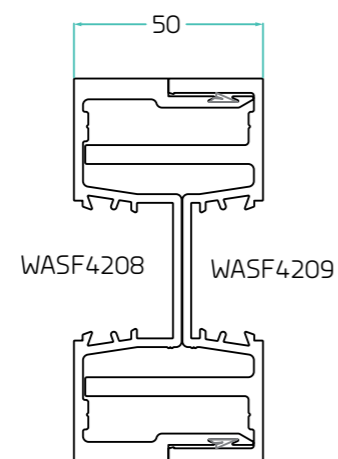

OUTSIDE

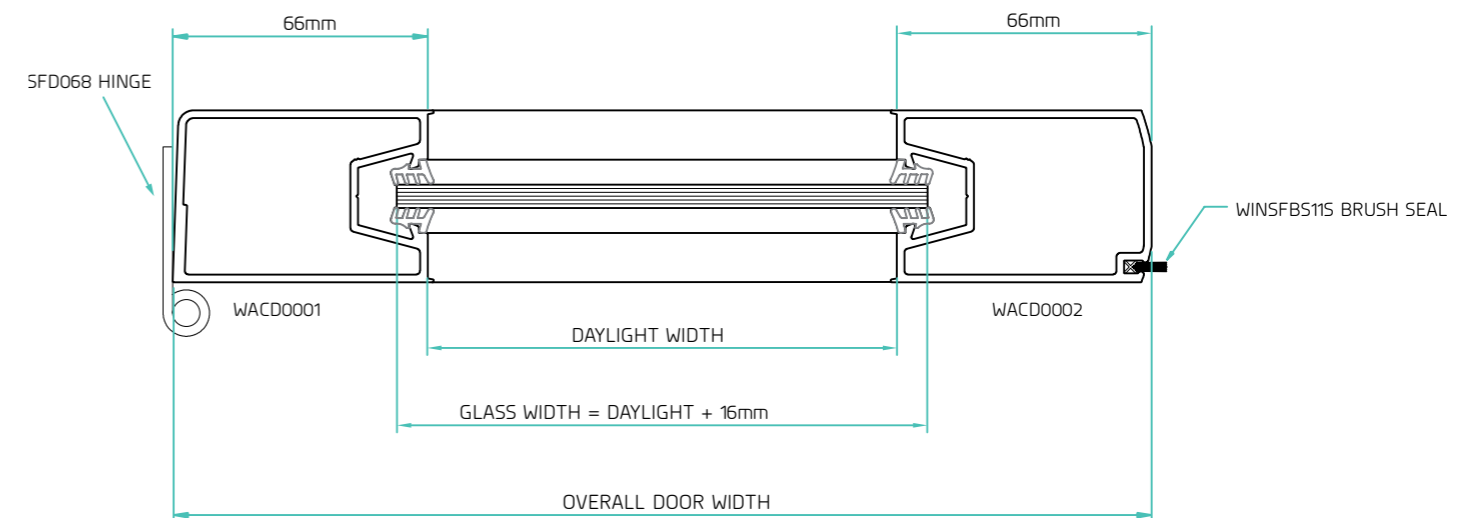
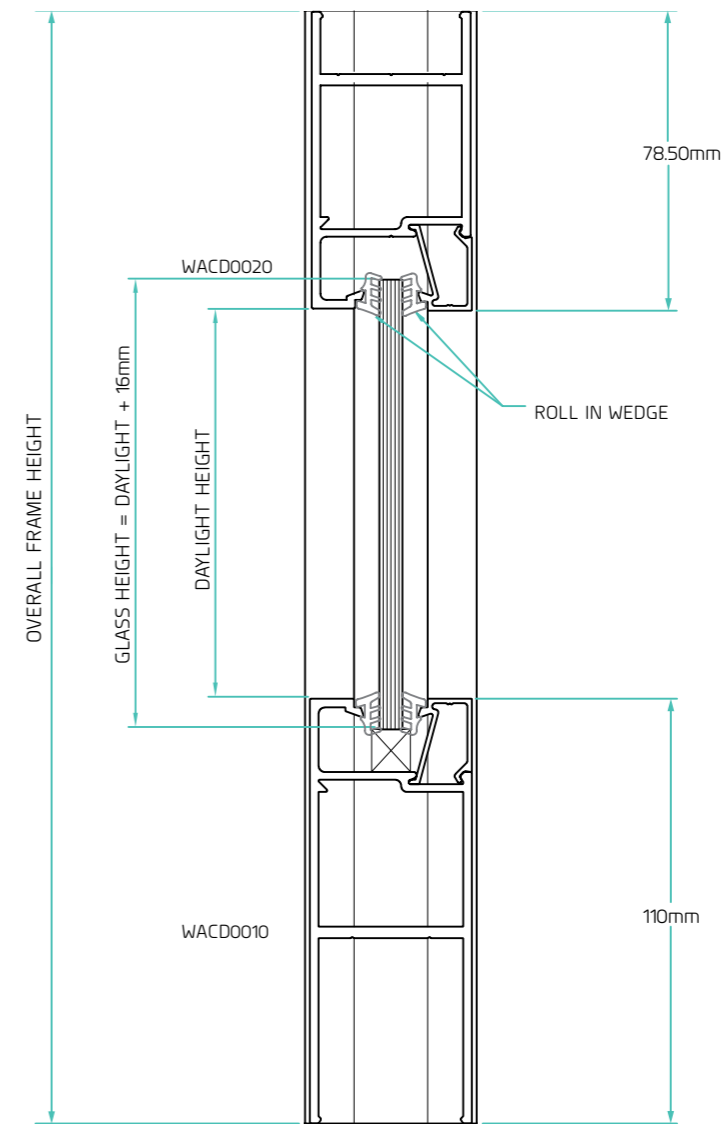

OUTSIDE

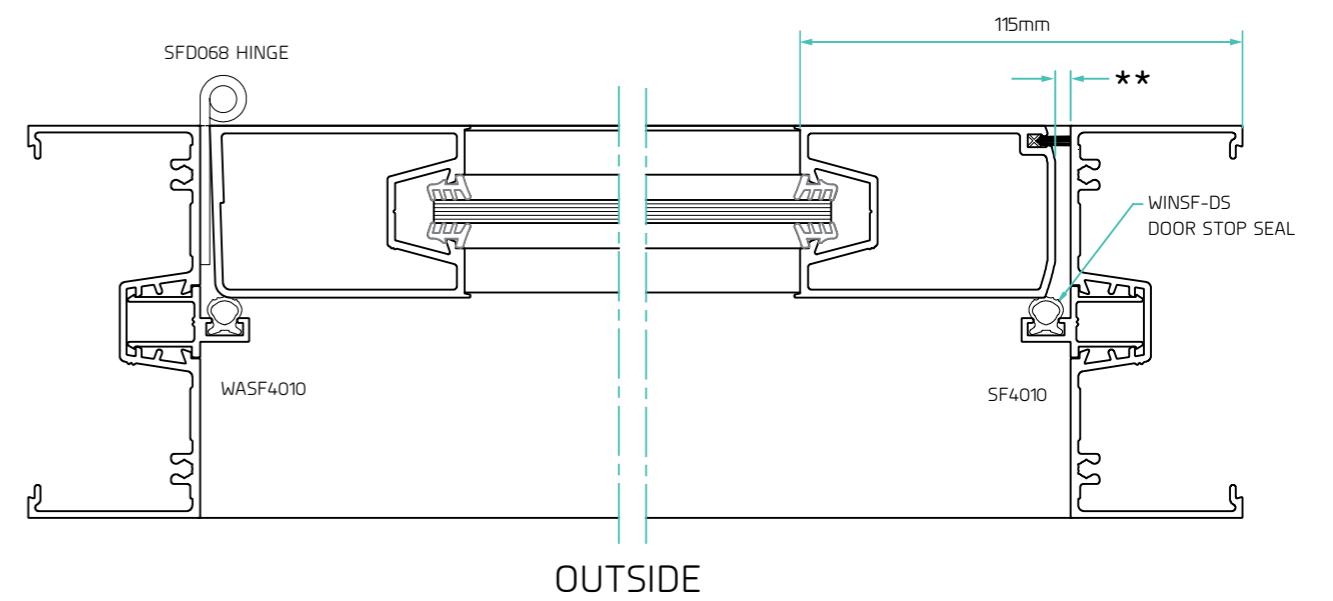
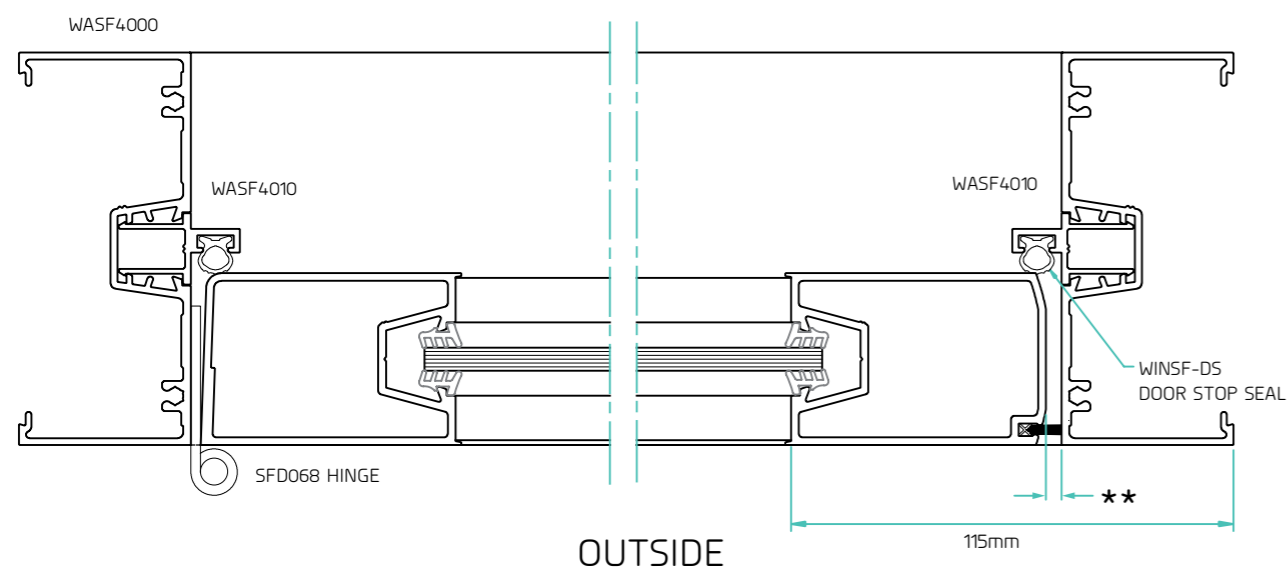
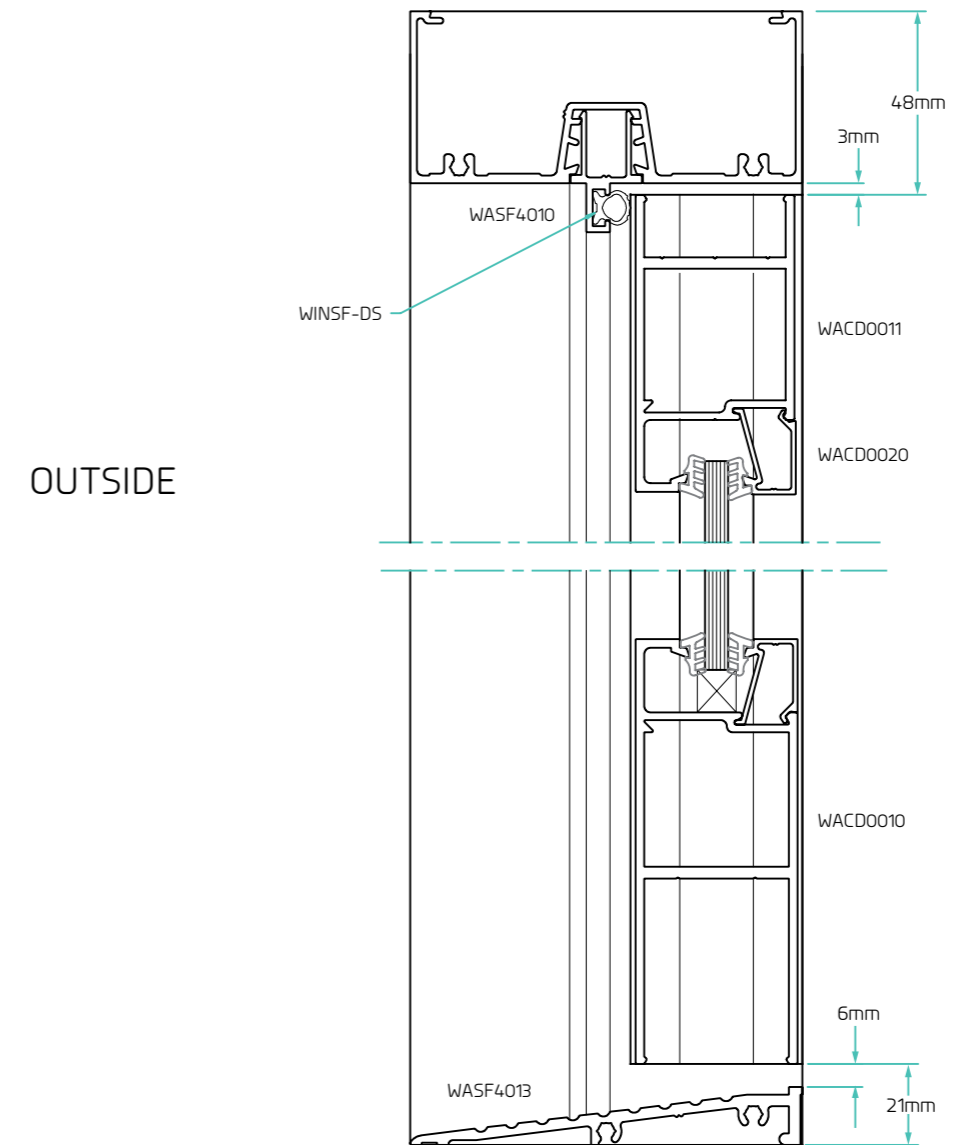
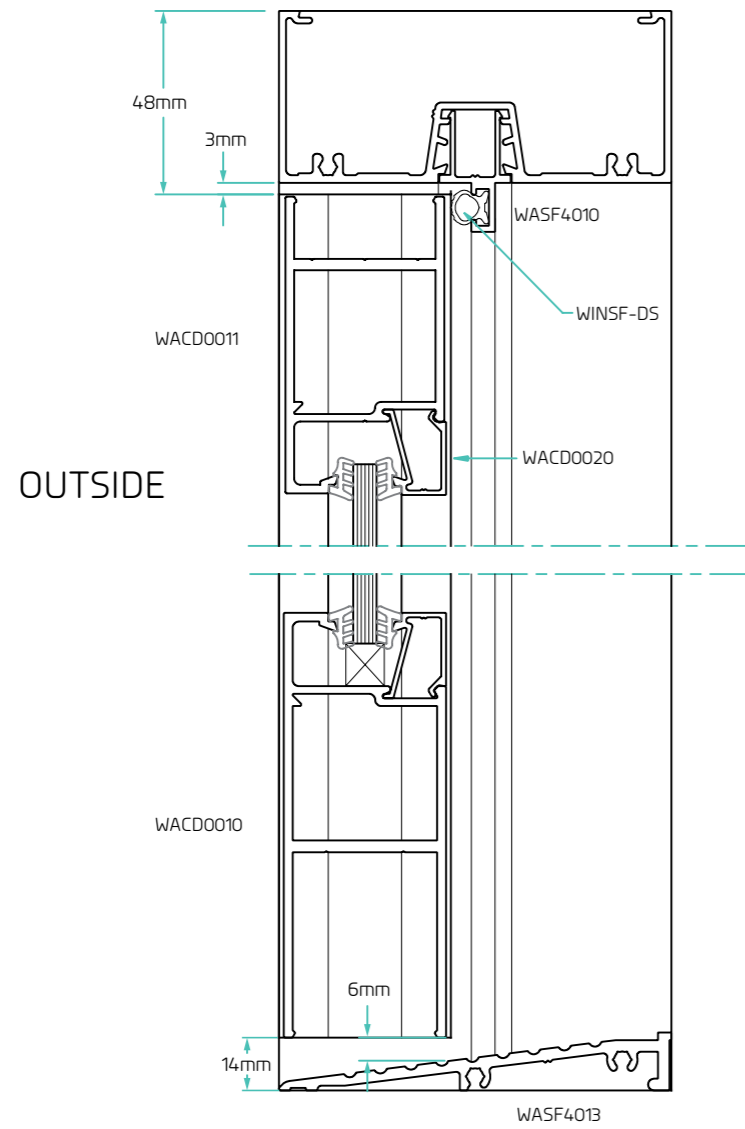

** 4mm for a flush mounted lock
6mm for a face fix striker

** 4mm for a flush mounted lock
6mm for a face fix striker

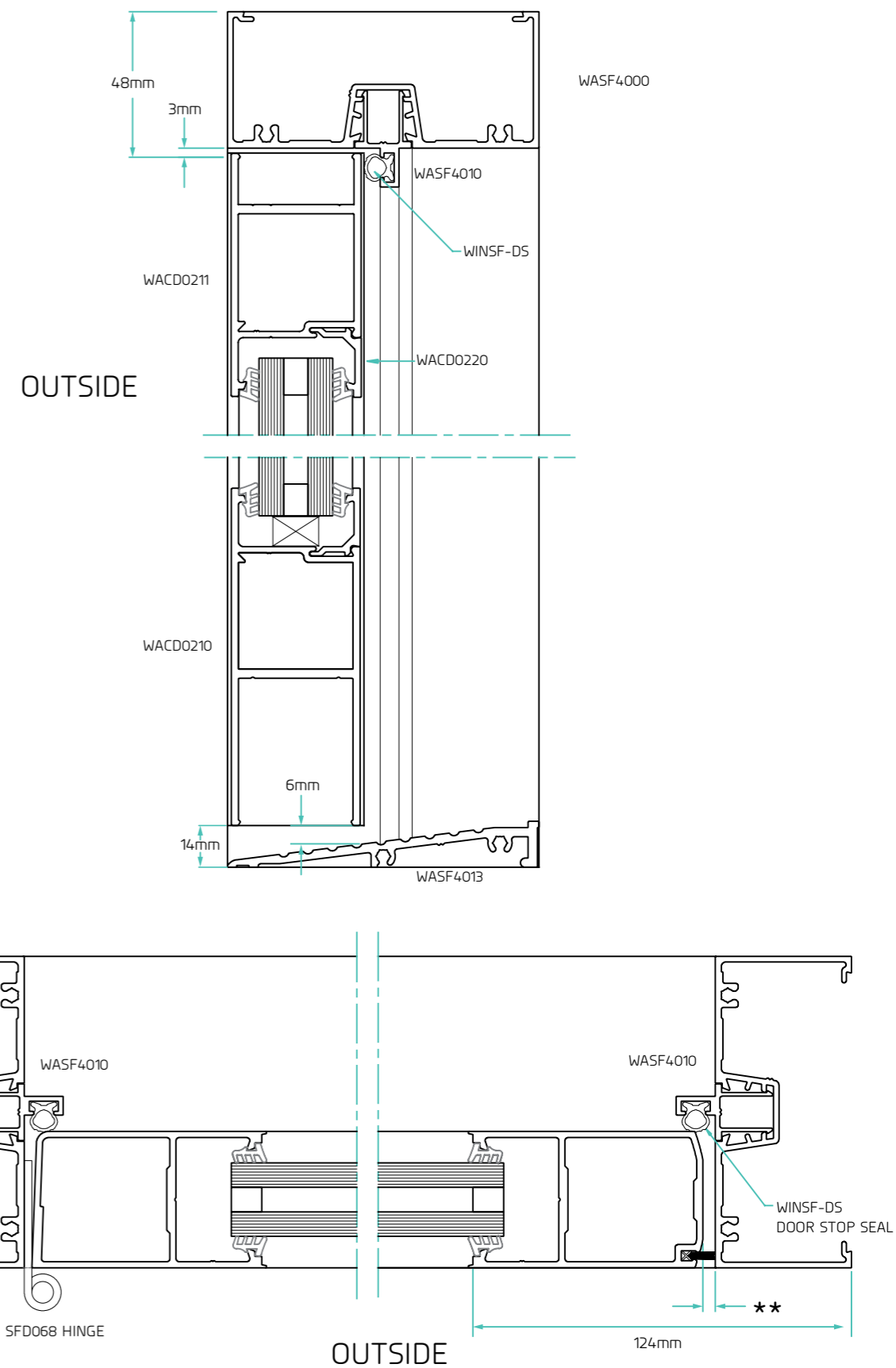
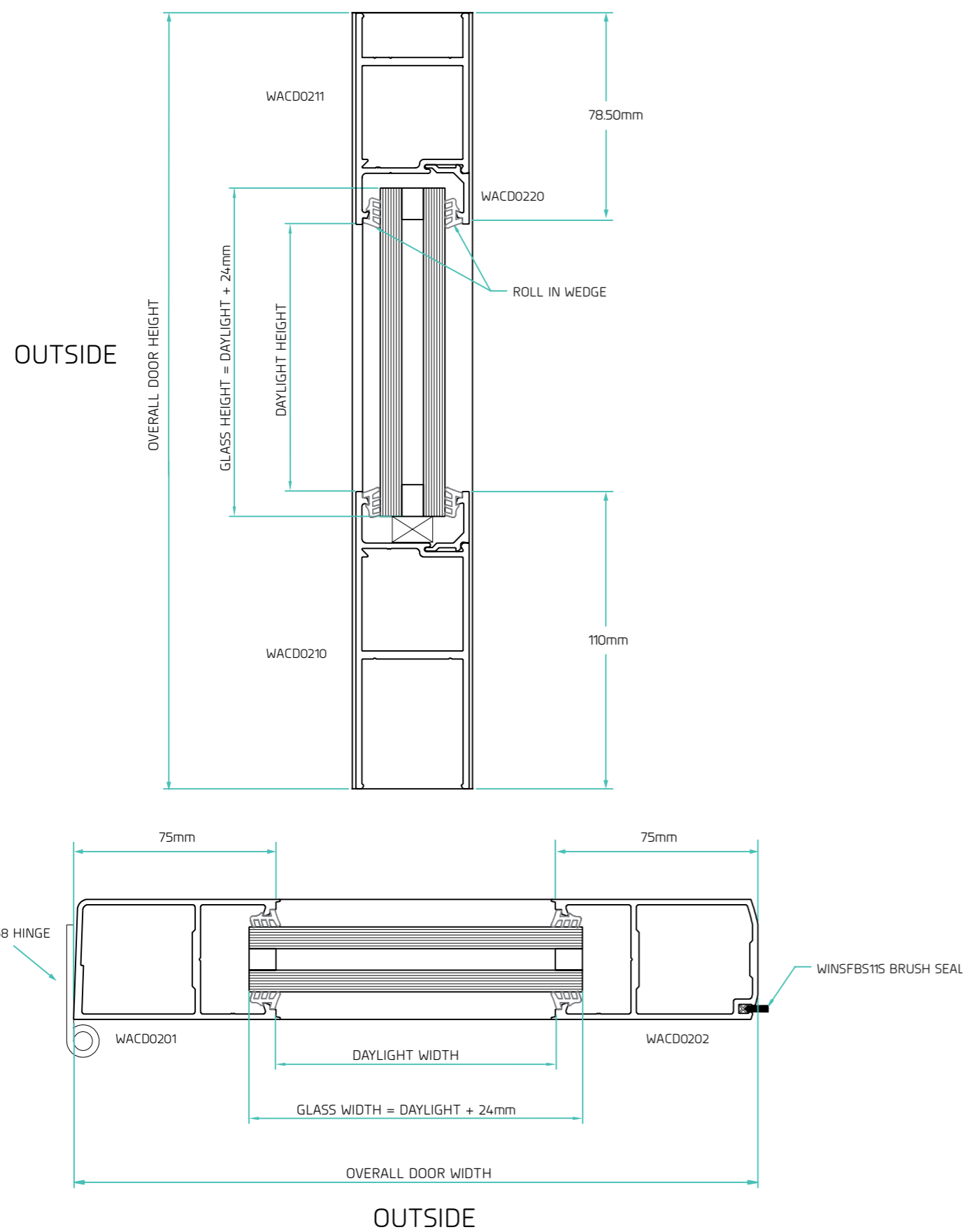

** 4mm for a flush mounted lock
6mm for a face fix striker

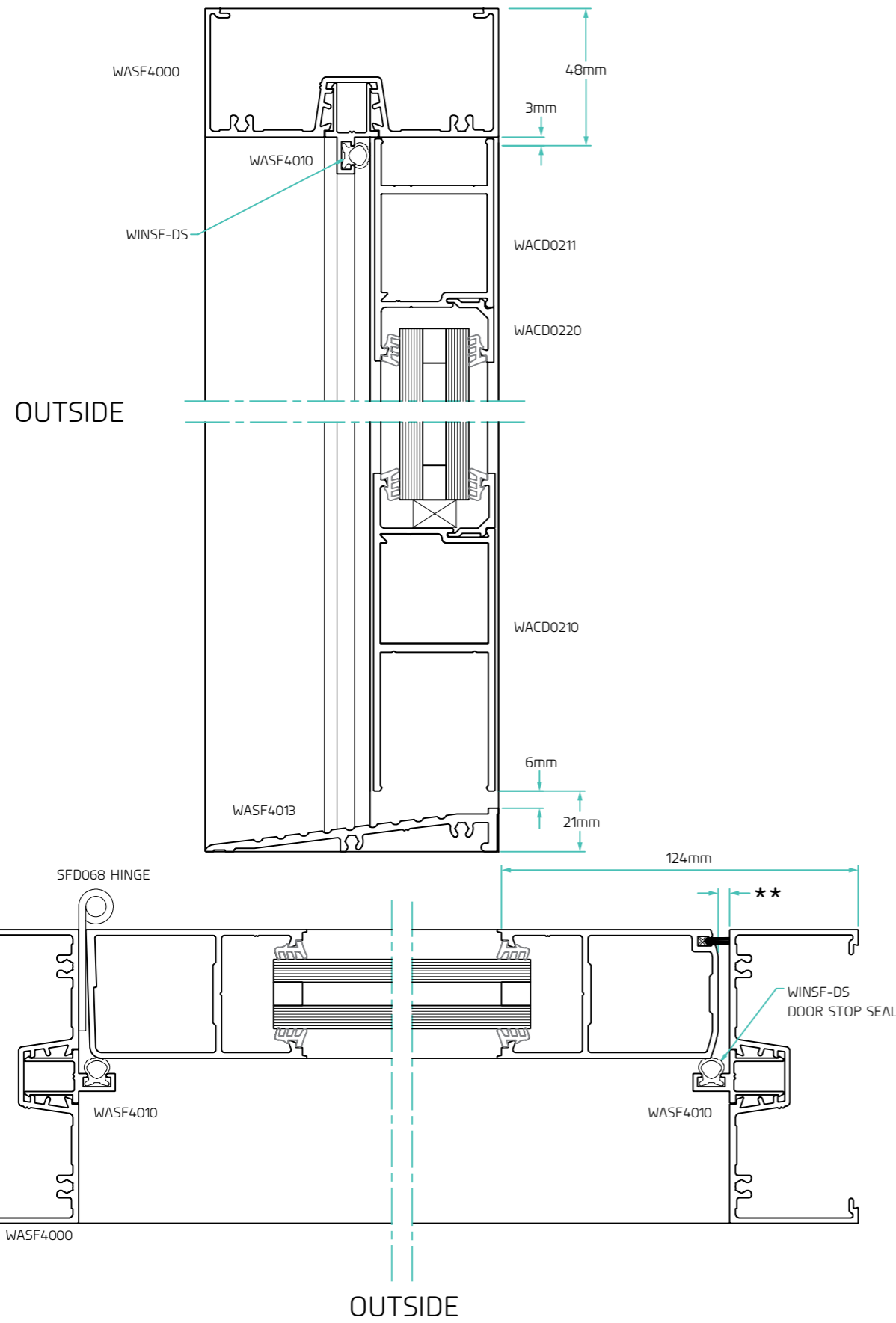

** 4mm for a flush mounted lock
6mm for a face fix striker

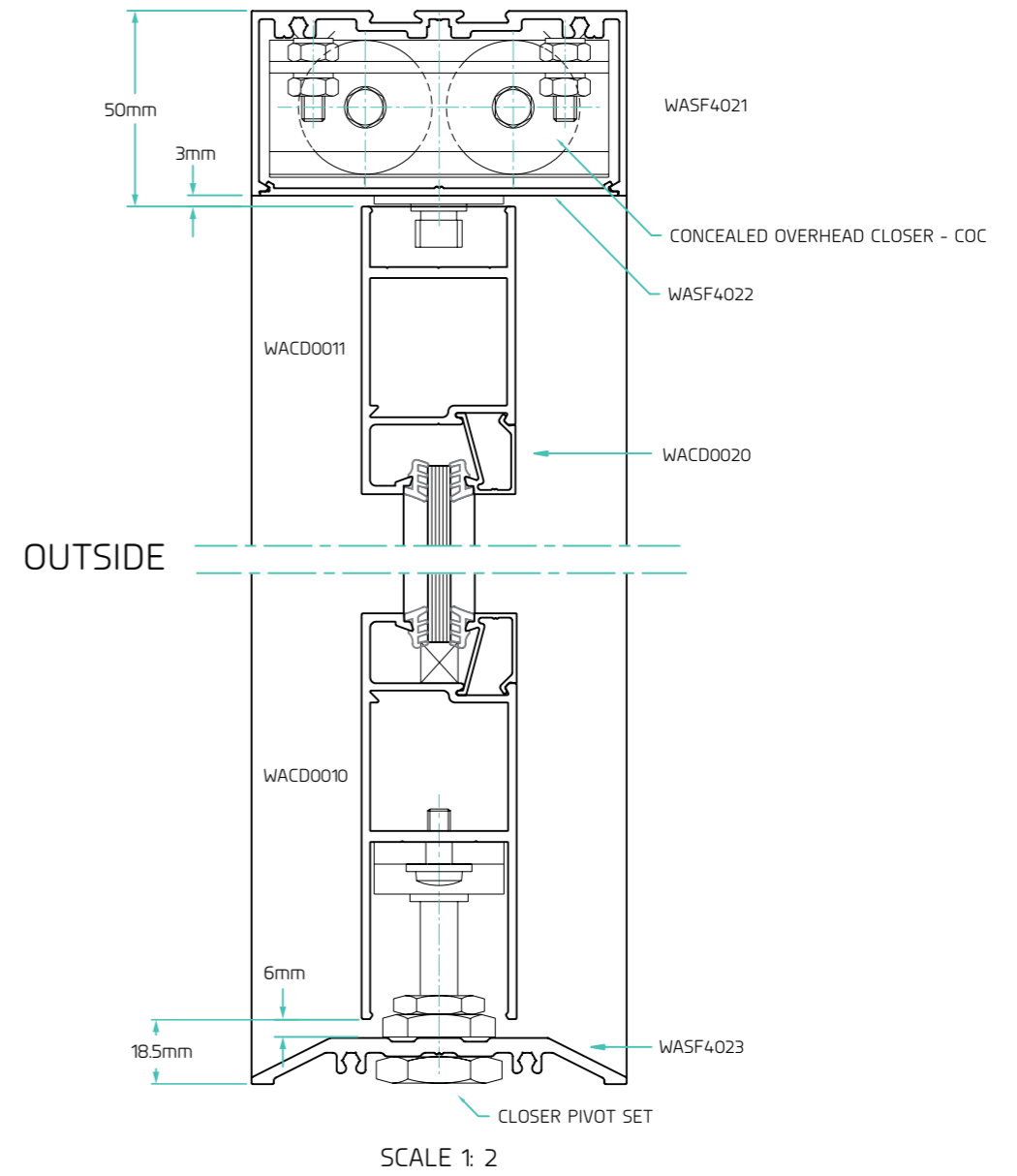

PAIR OF PIVOT DOORS

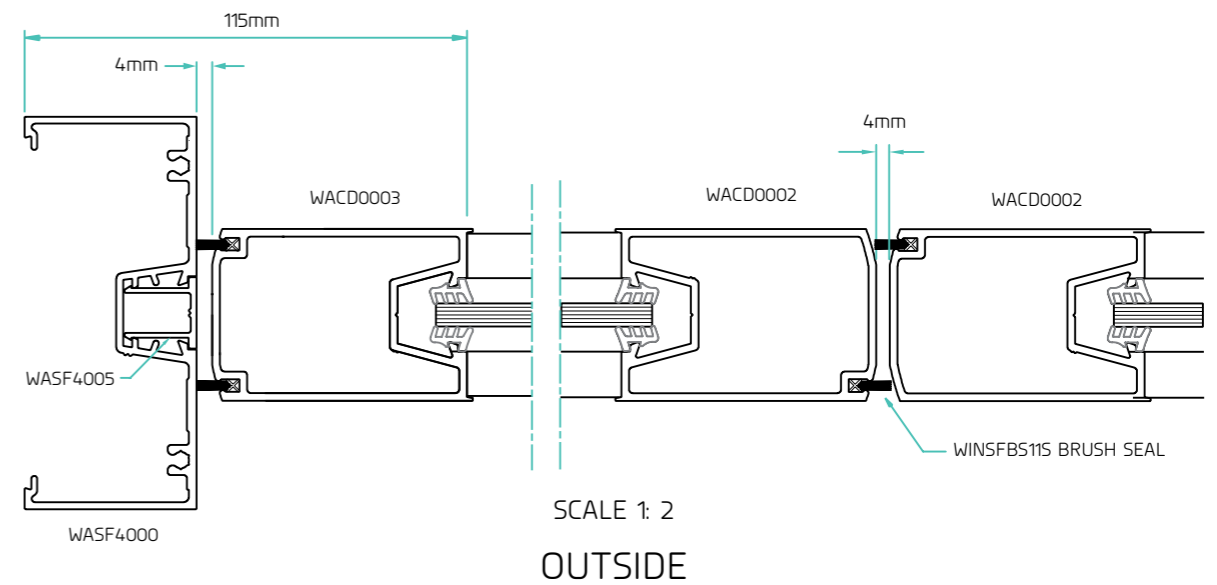

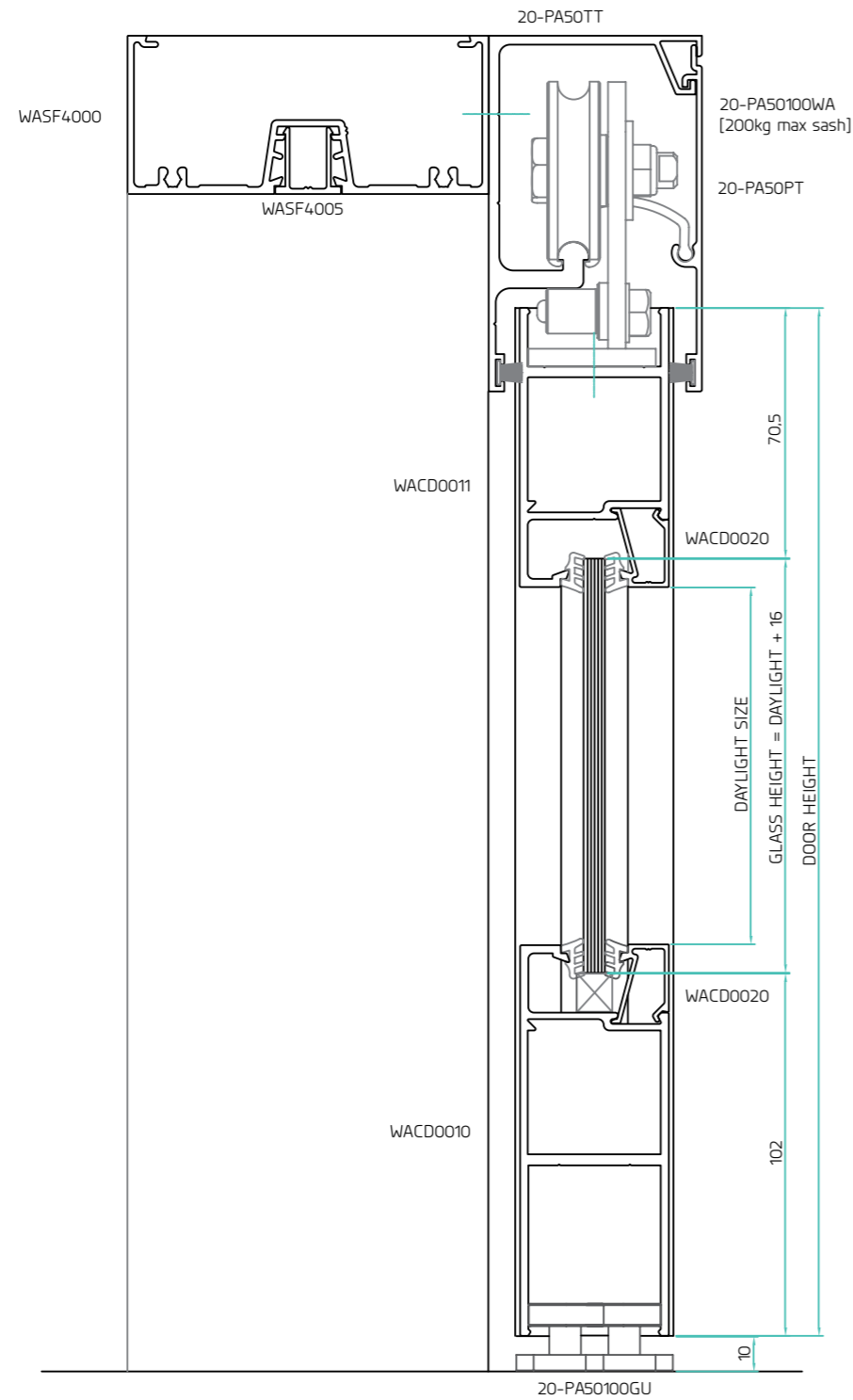

OPTION 1

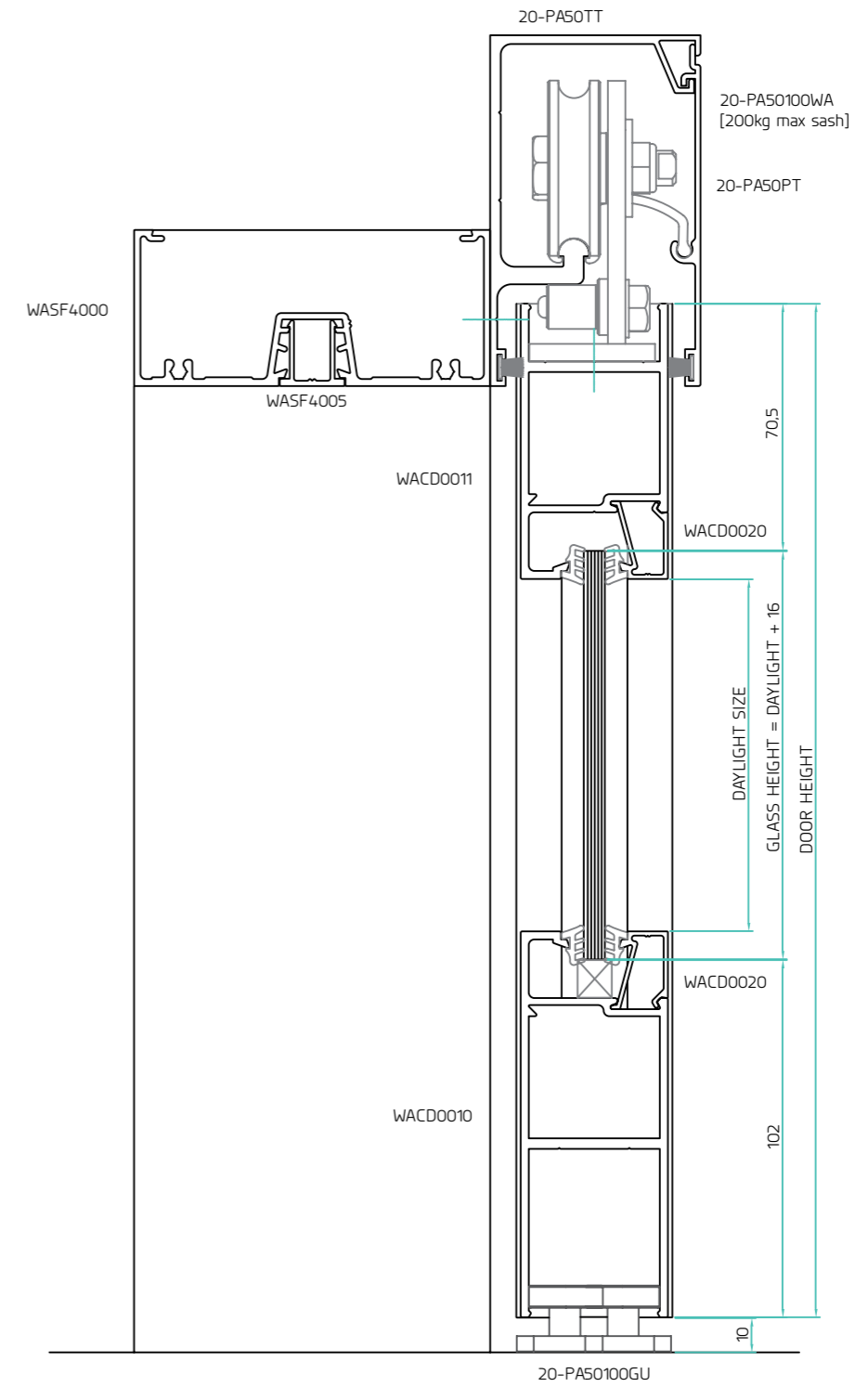

OPTION 2

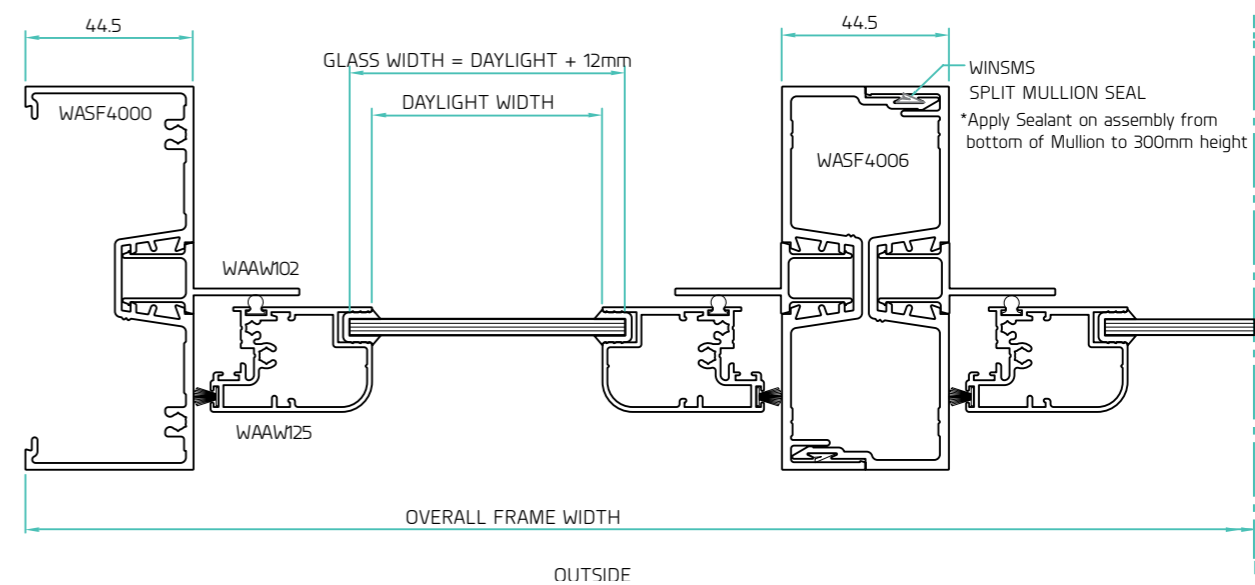
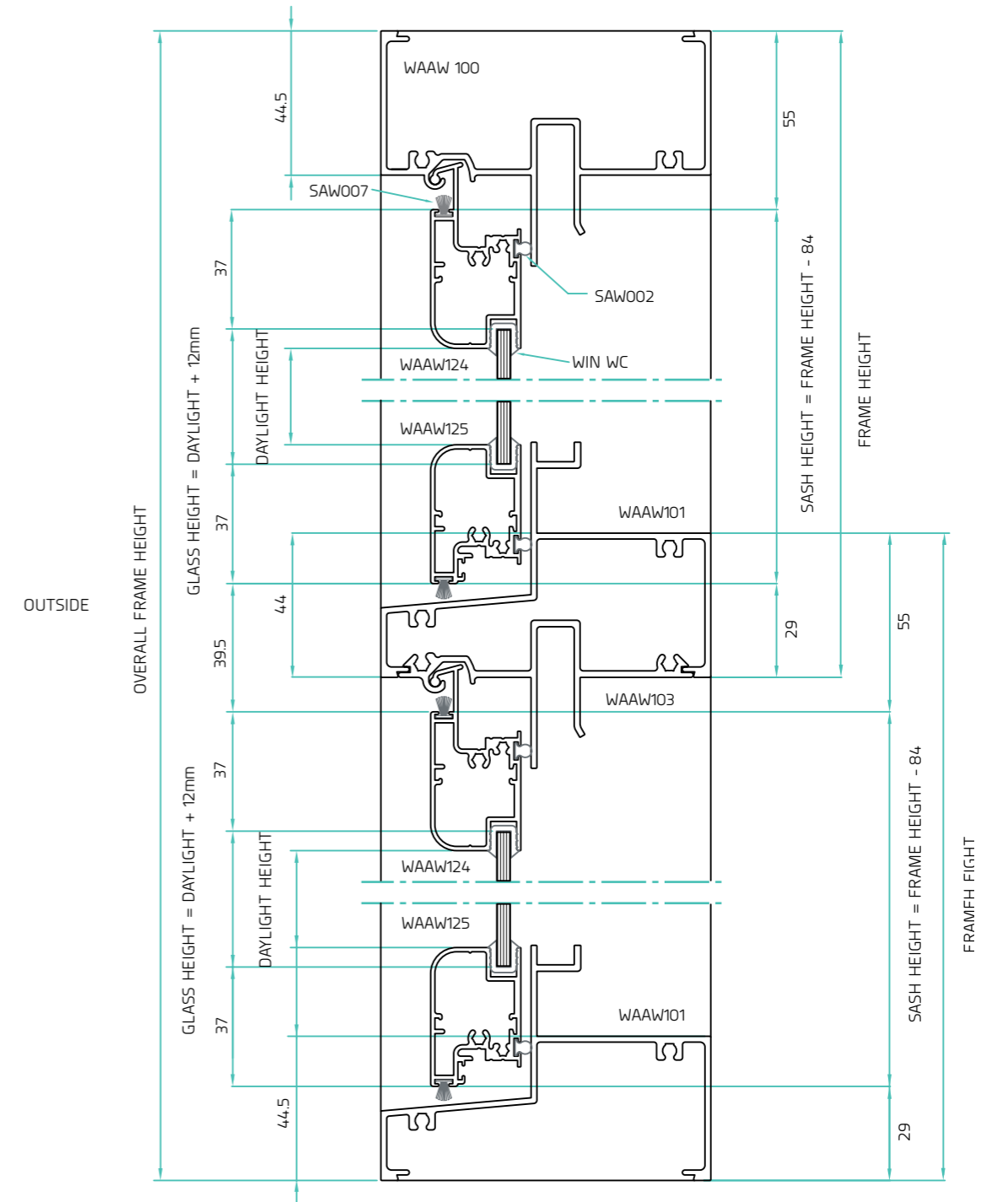
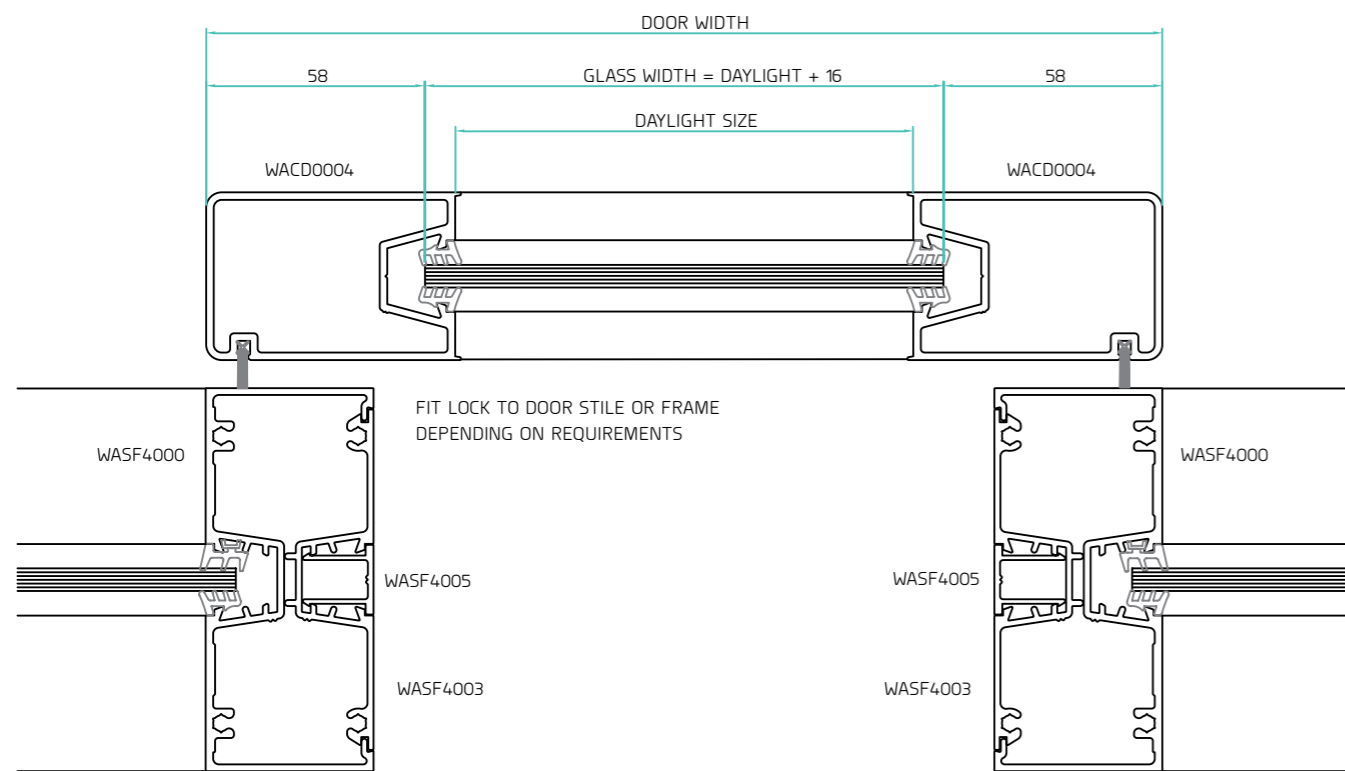

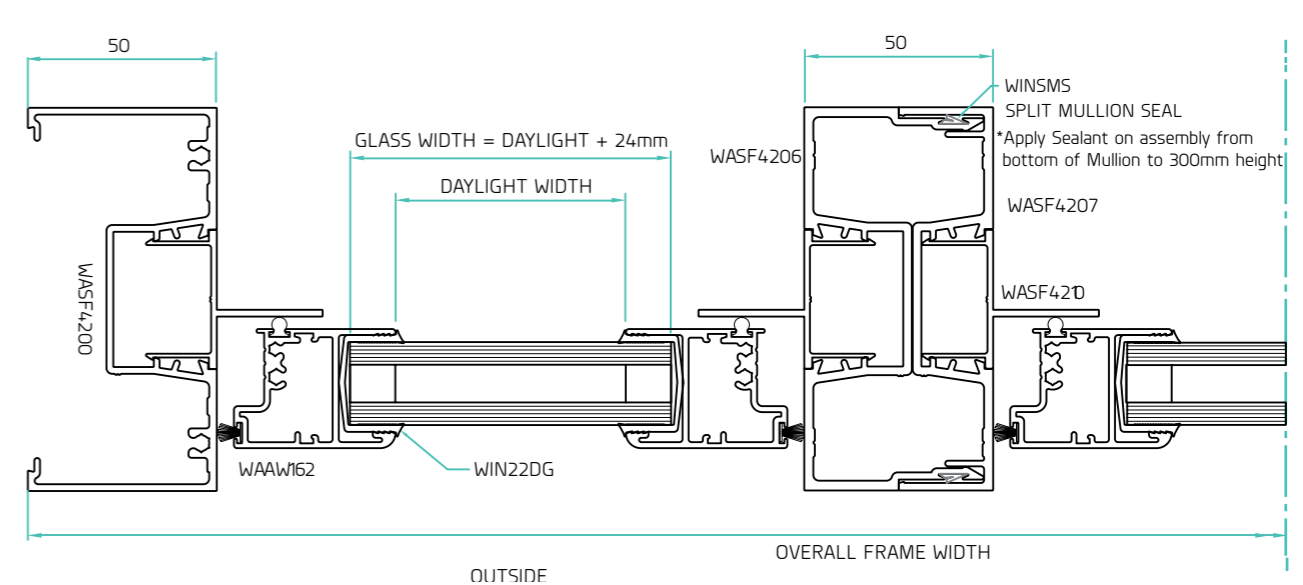
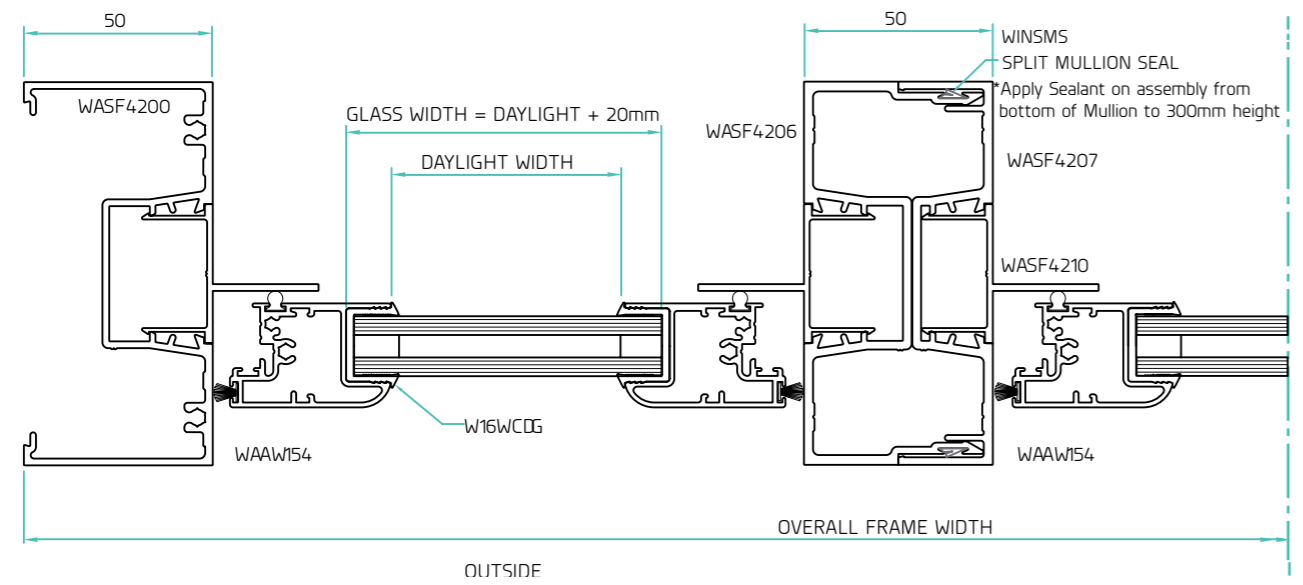
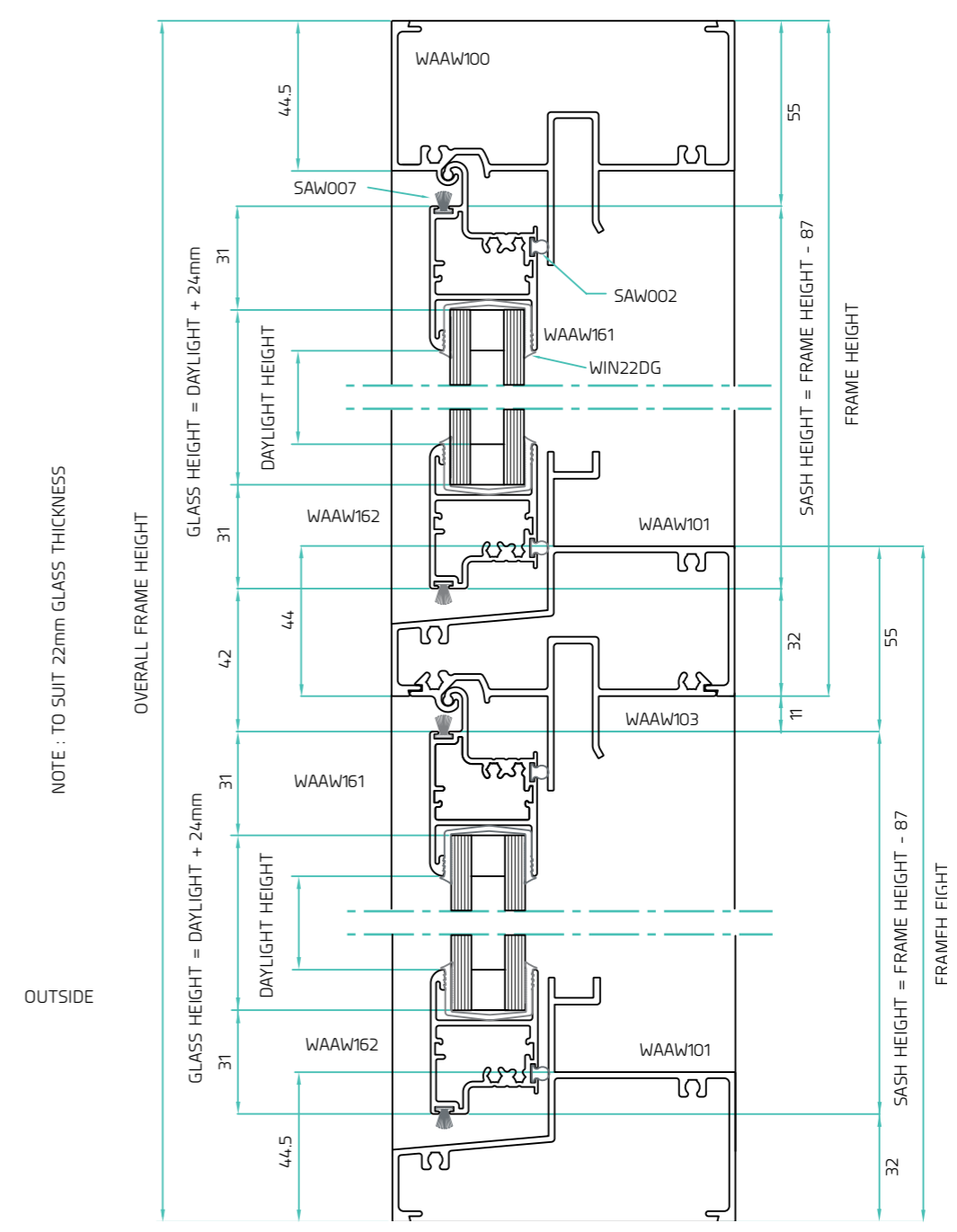
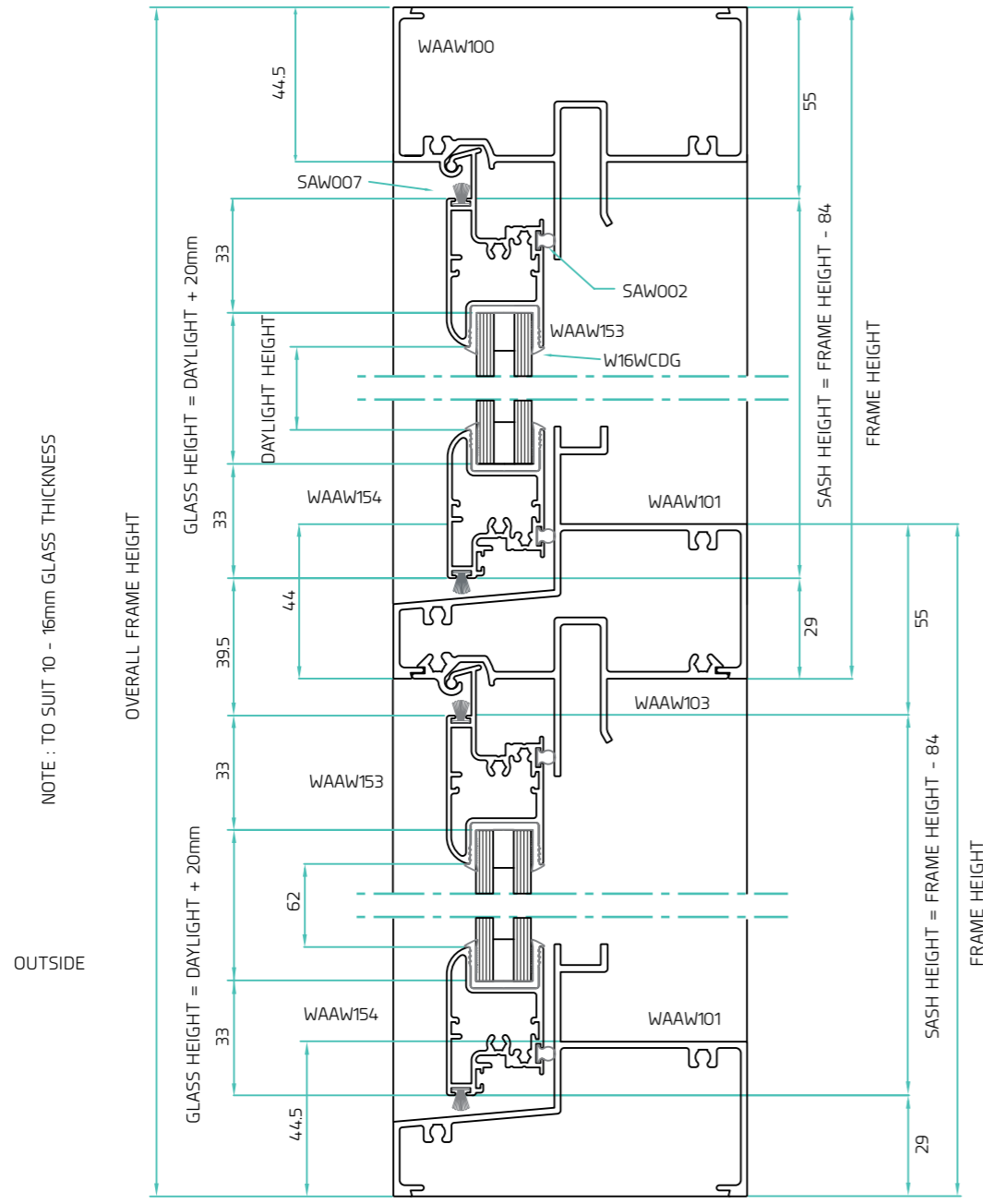



MACHINING
DETAILS

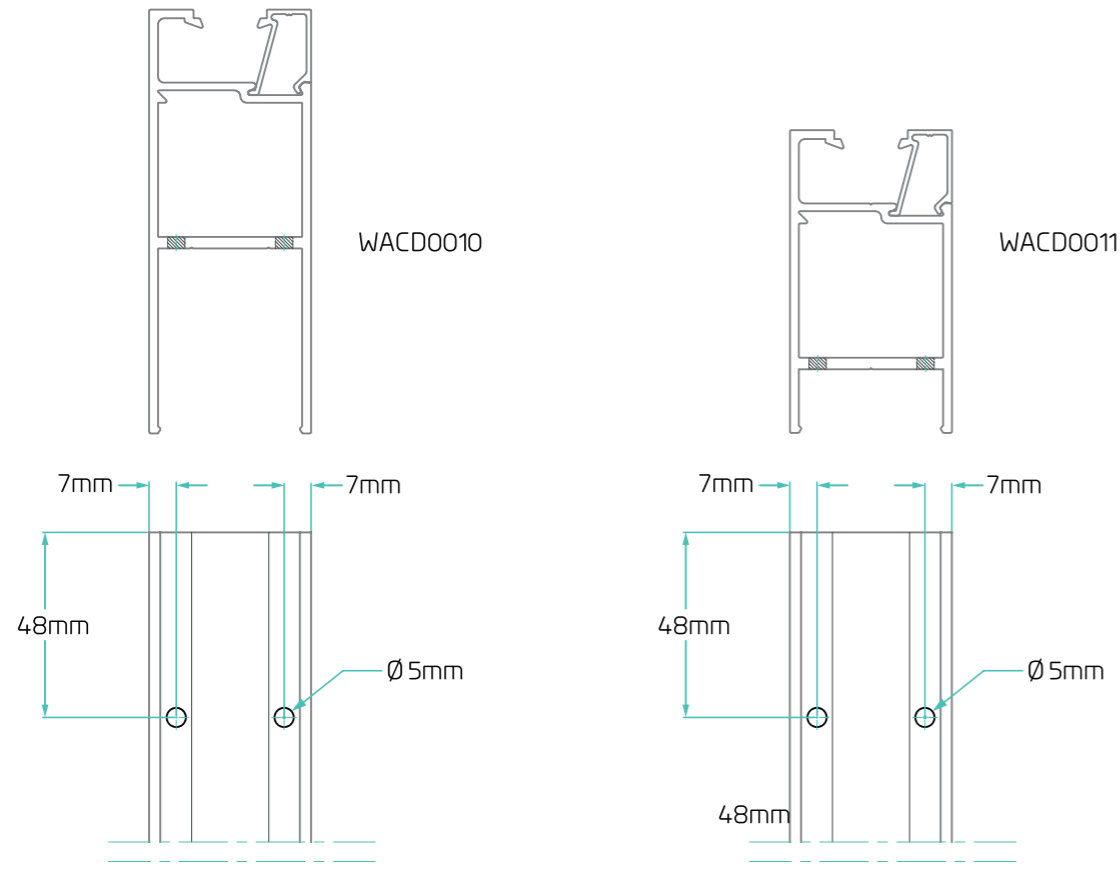

DOOR RAIL FIXING HOLE DETAIL - BOTH ENDS

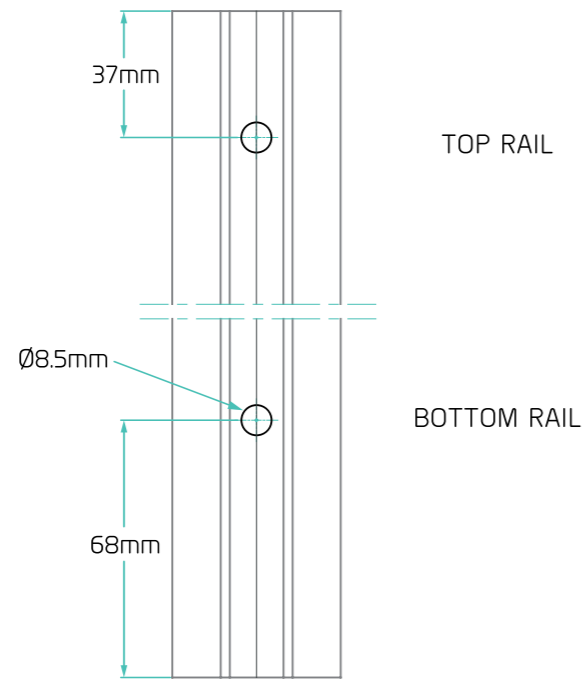

TOP RAIL

BOTTOM RAIL

ALL DOOR STILES
EXAMPLE SHOWN - WACD0002

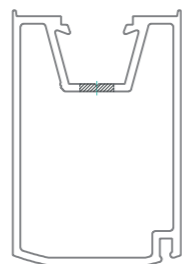

DOOR STILE FIXING HOLE DETAIL

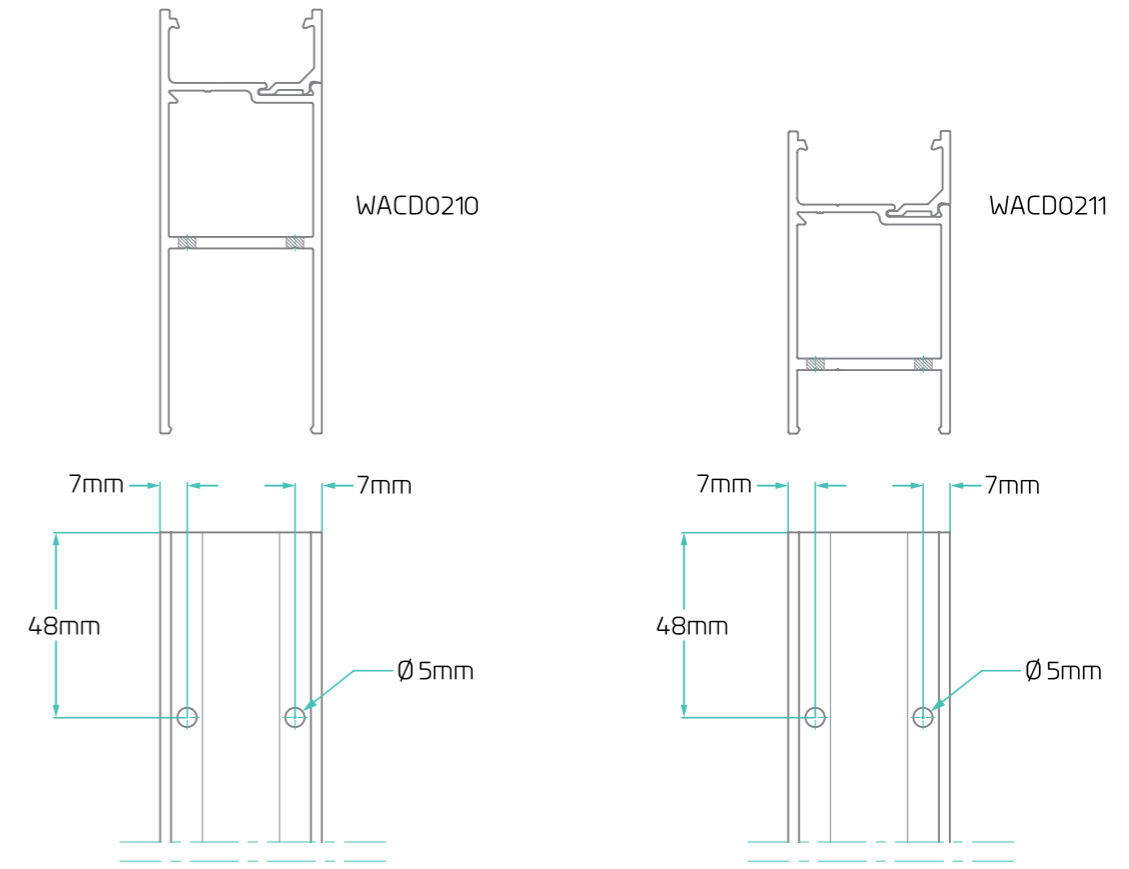

DOOR RAIL FIXING HOLE DETAIL - BOTH ENDS

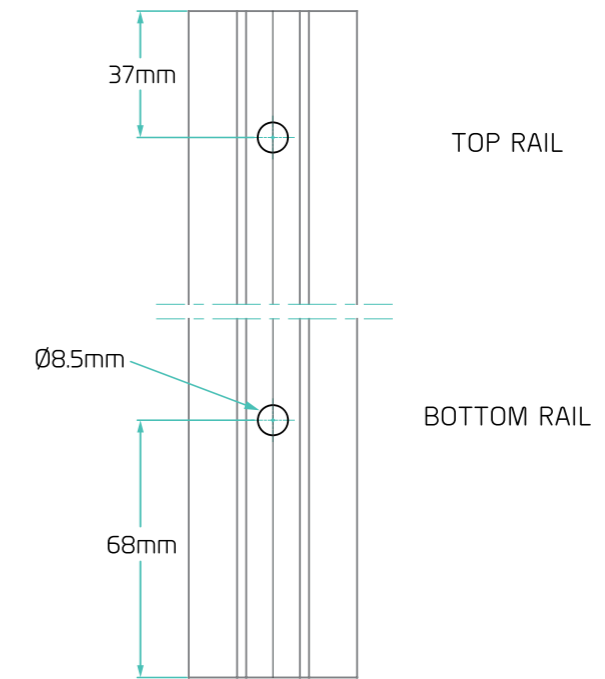

TOP RAIL

BOTTOM RAIL

ALL DOOR STILES
EXAMPLE SHOWN - WACD0202

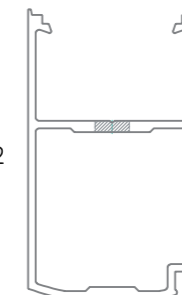

DOOR STILE FIXING HOLE DETAIL

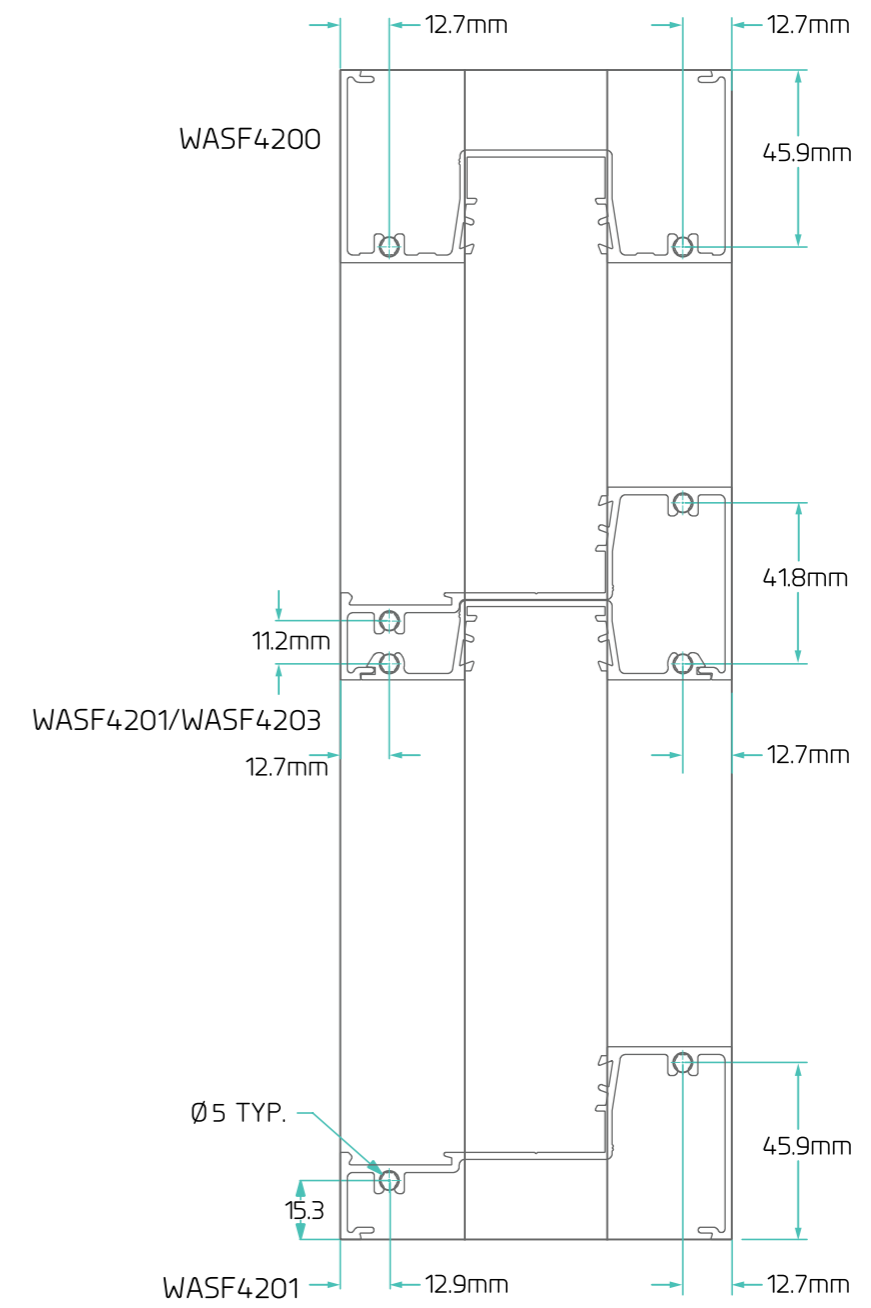
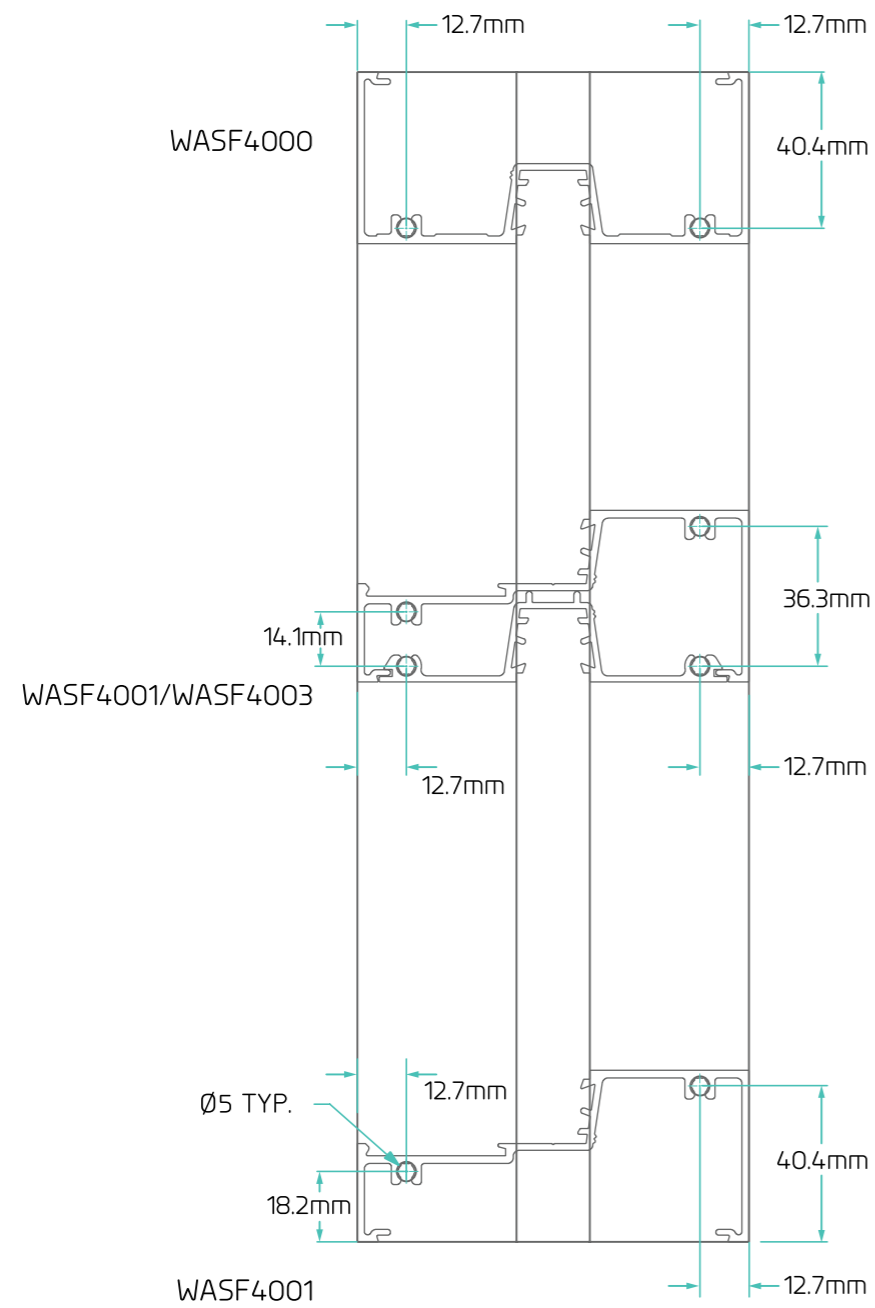
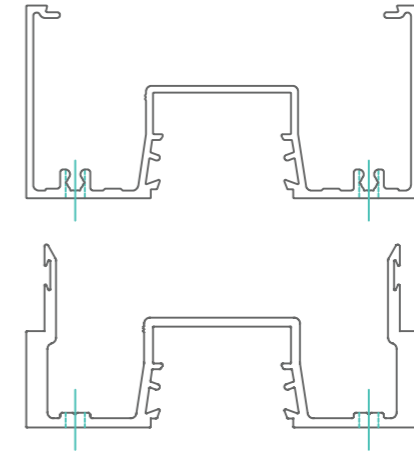
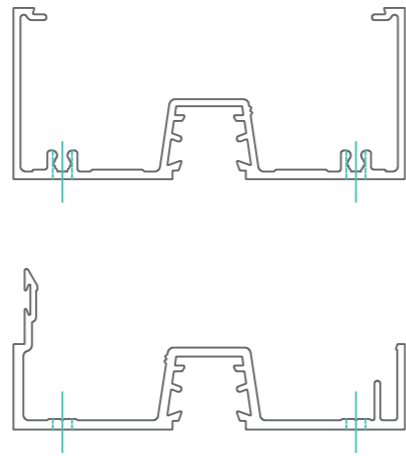

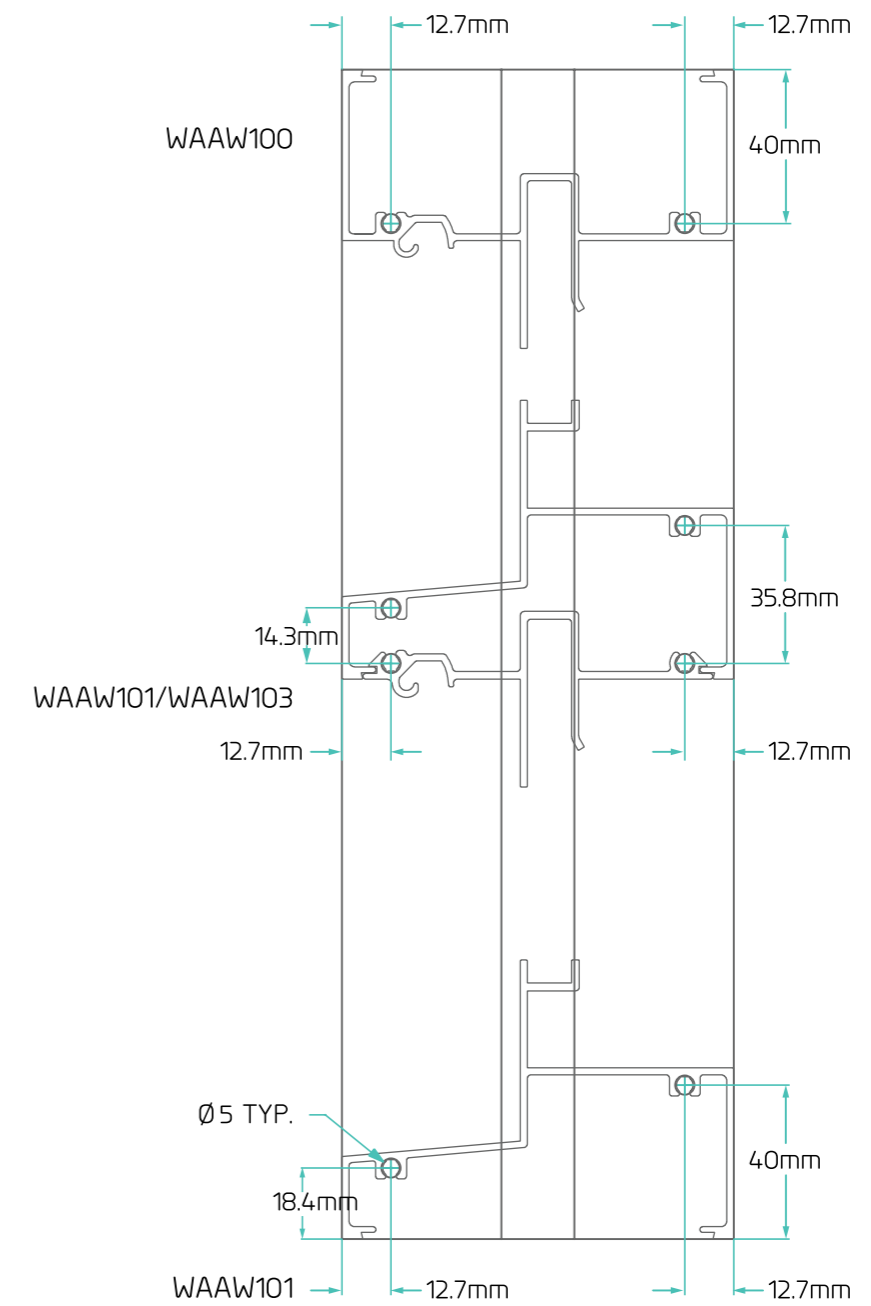
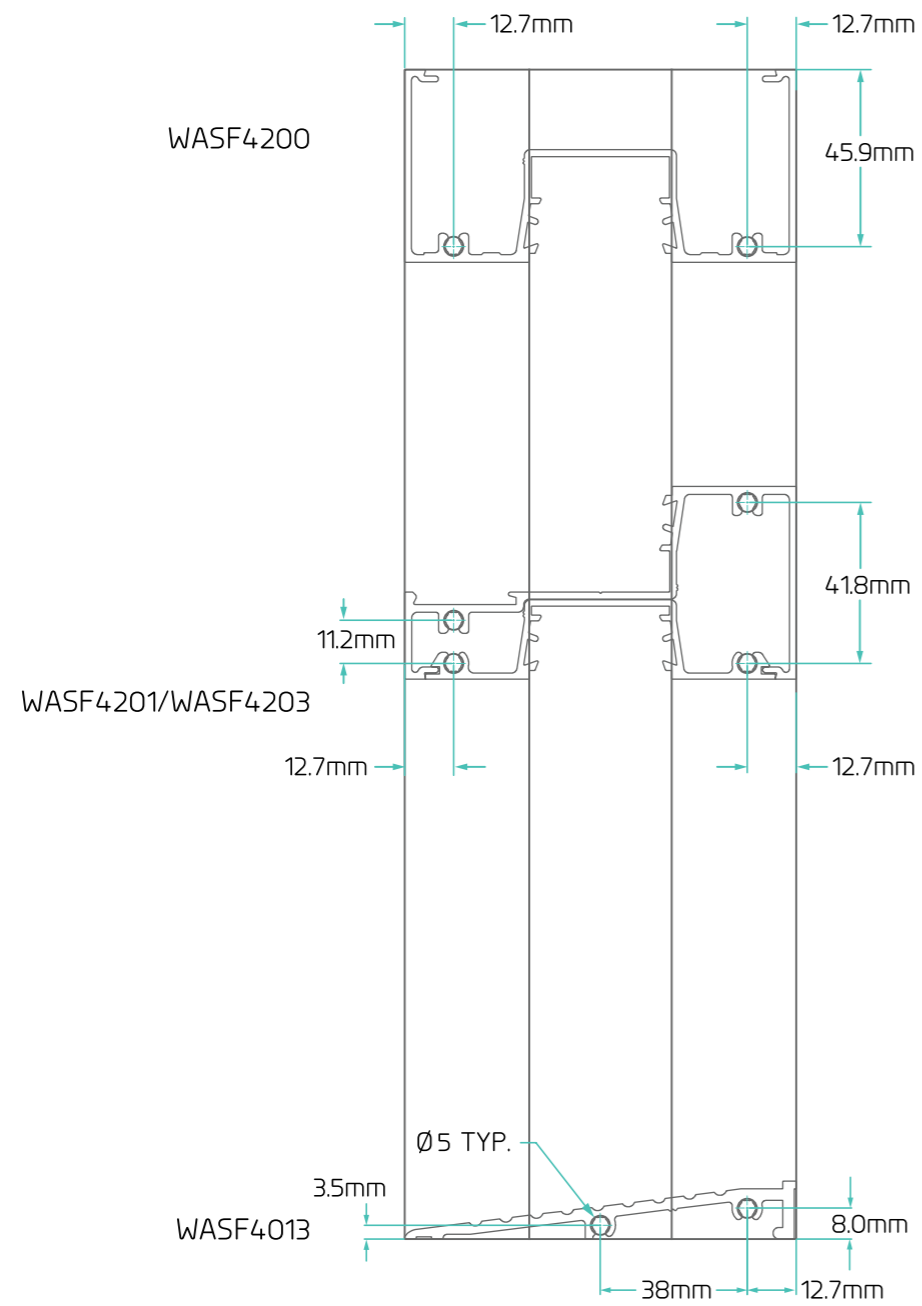
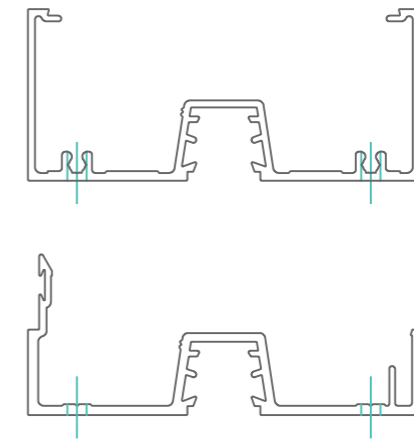
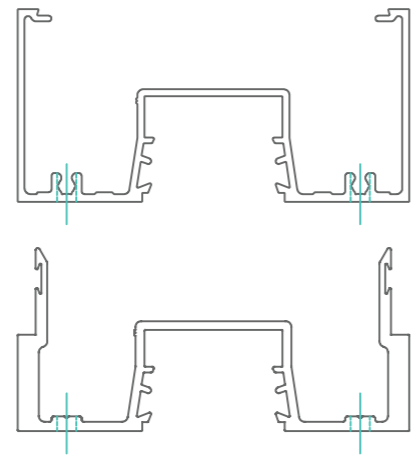

SCALE 1:2

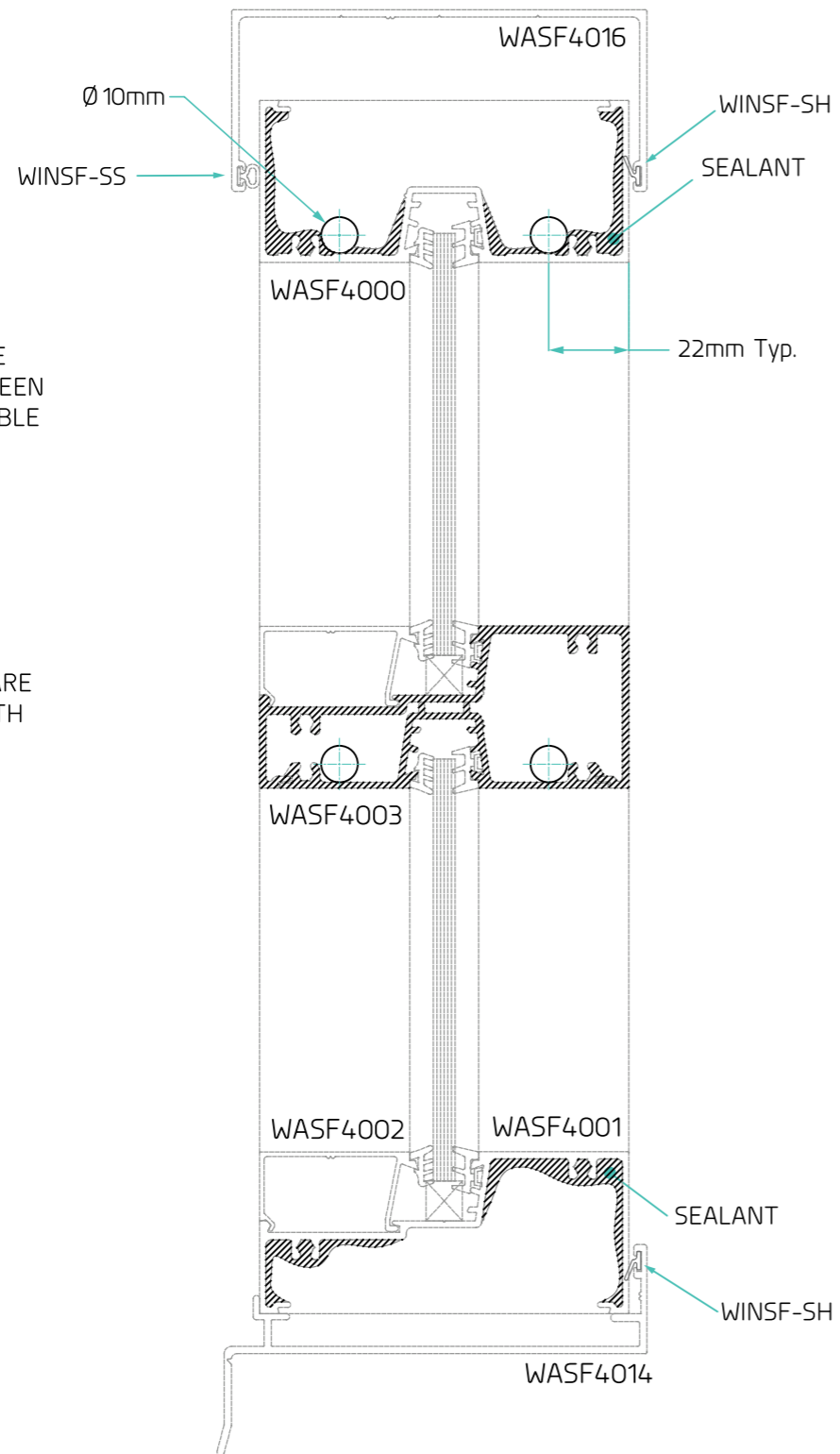

NOTE:
DRAIN HOLES ARE
UNIVERSAL BETWEEN
SINGLE AND DOUBLE
GLAZED FRAMES.

NOTE:
ALL TRANSOMS ARE
BUTT SEALED WITH
SEALANT

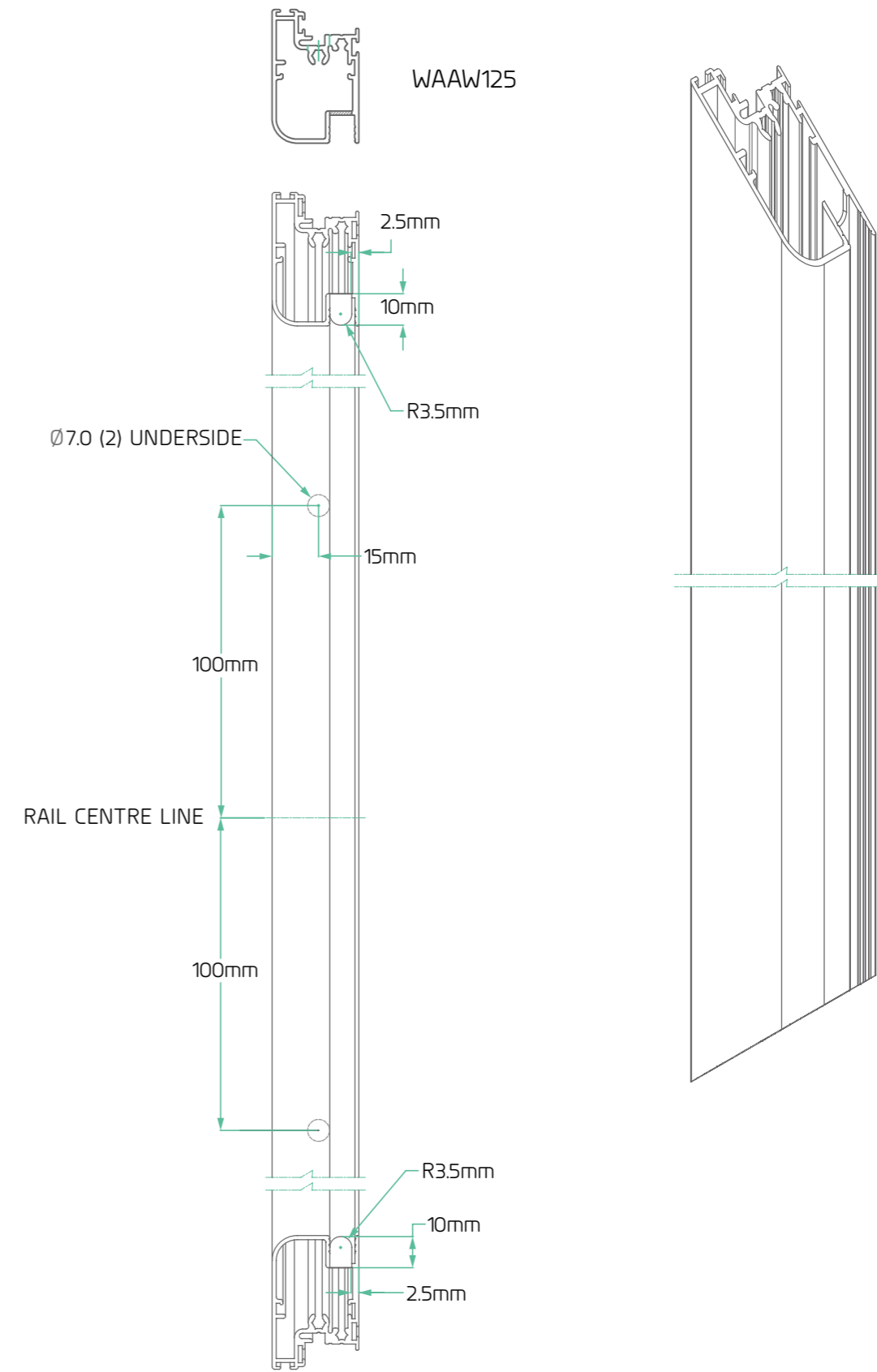

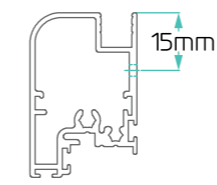
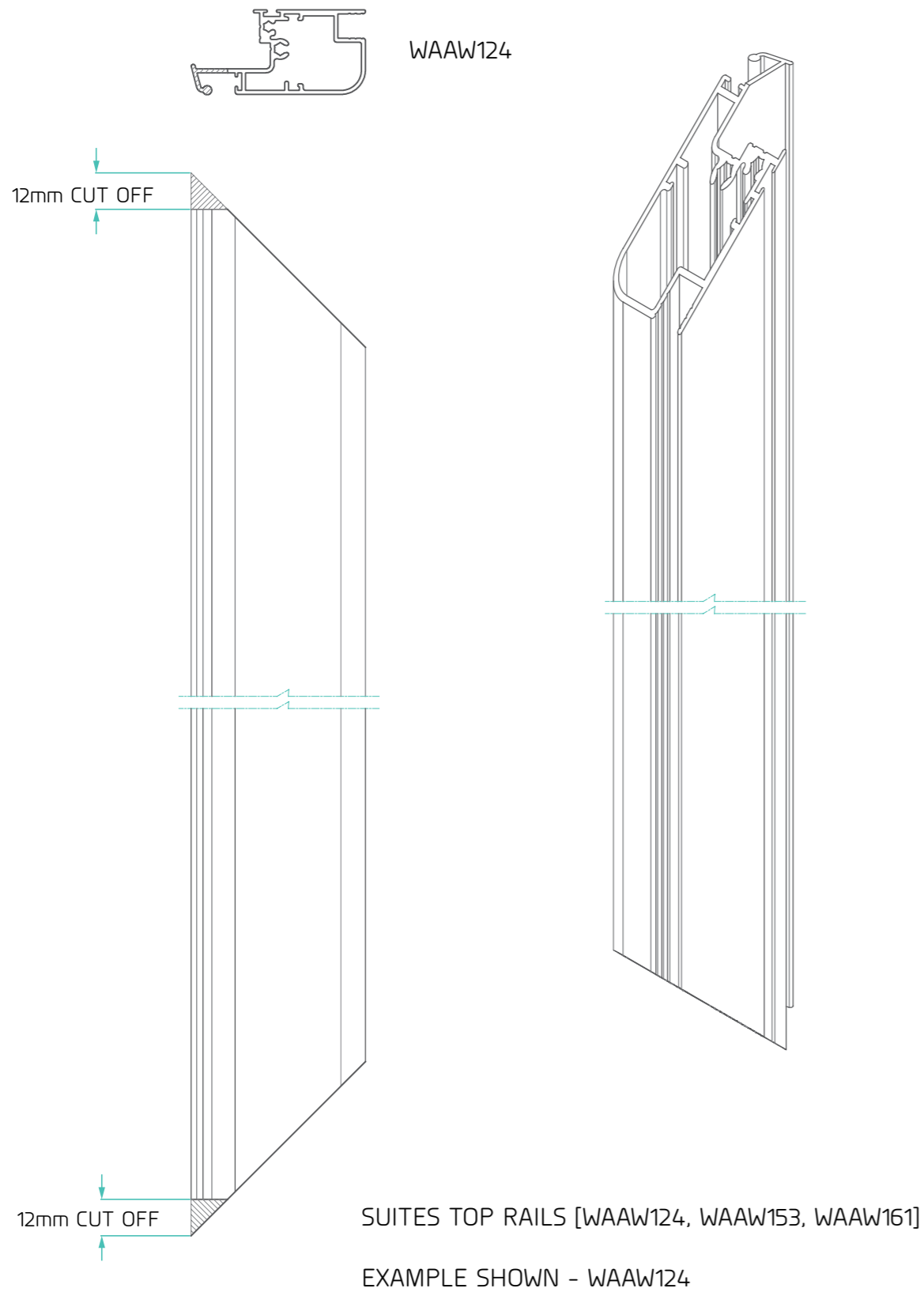

WAAW125

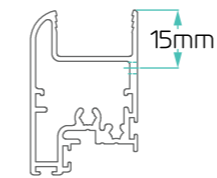

WAAW154

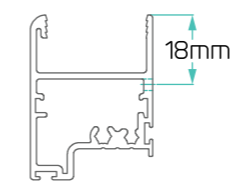

WAAW162

FIXINGS FOR CHAIN WINDER

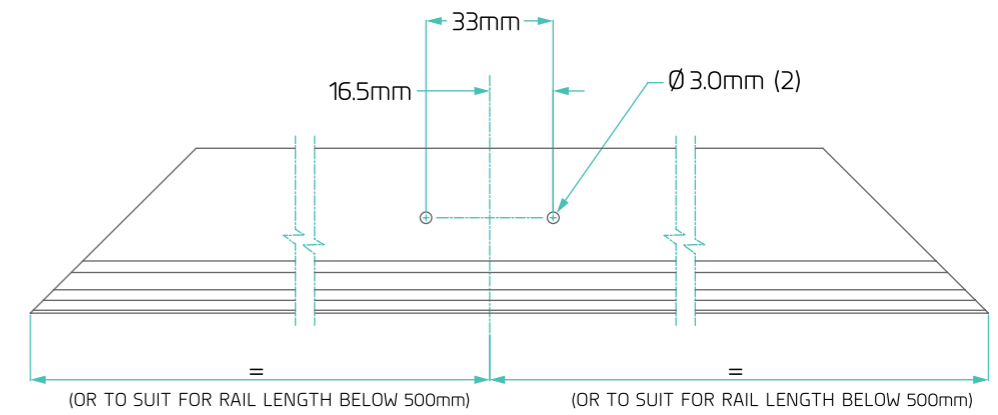
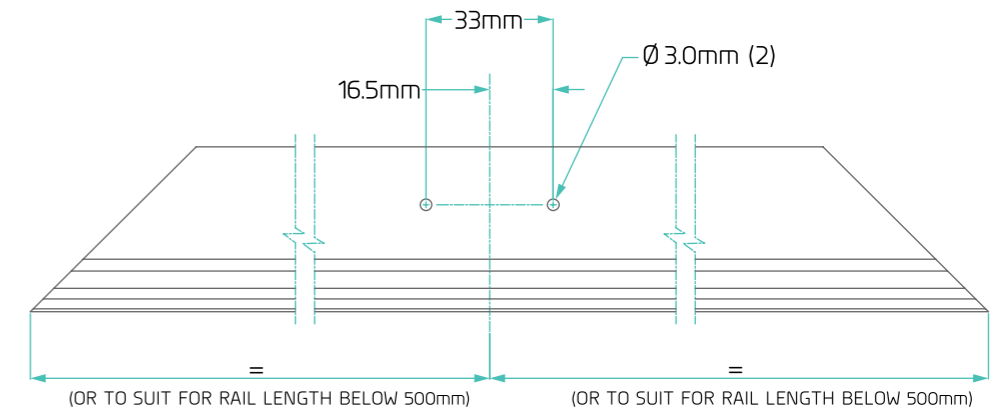

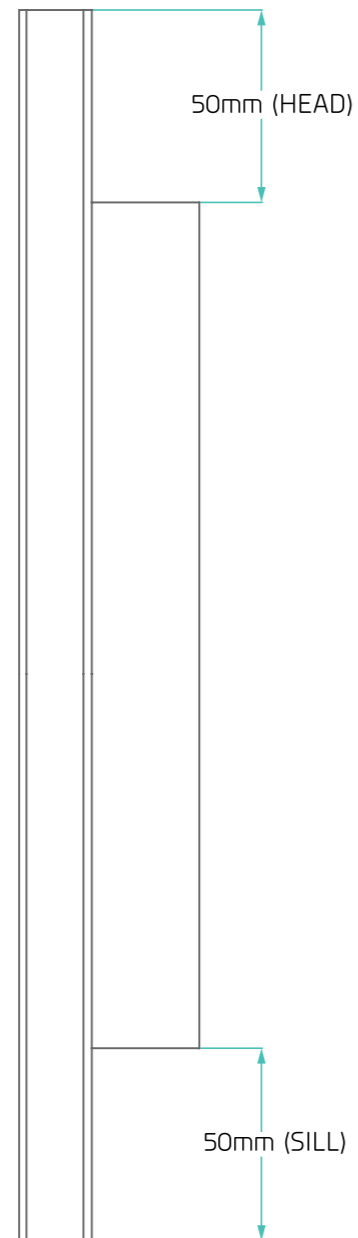
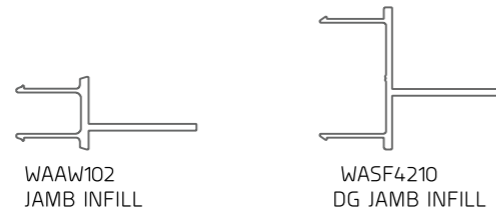

NOTE: CUTOUT IS THE SAME FOR BOTH ENDS

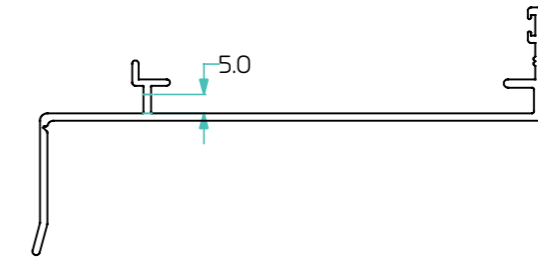

WASF4015

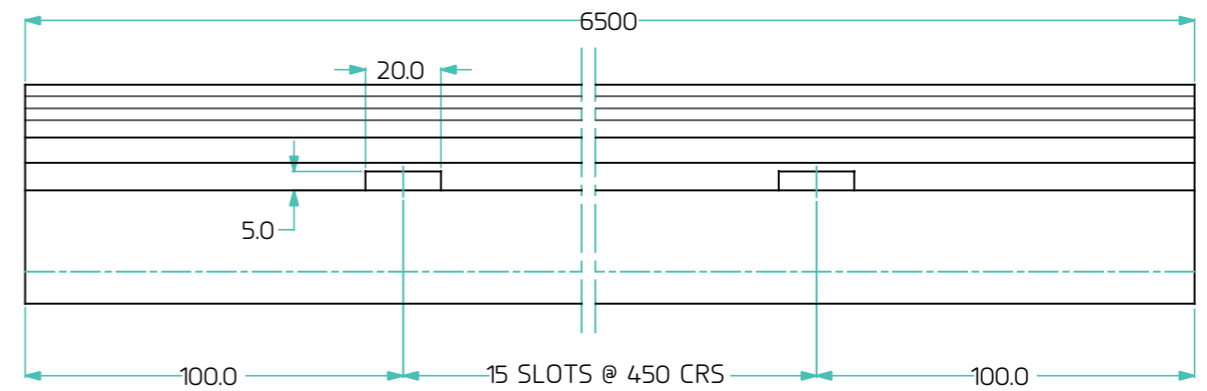

SLOT DETAILS

SUITES SUBSILLS [WASF4014, WASF4015 WASF4024

EXAMPLE SHOWN - WASF4015

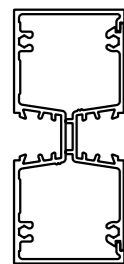

+ MULLION COMBINATION WASF4000/WASF4003
DEFLECTION LIMITED TO SPAN/250

These tables are based on theoretical section mechanical properties, not on approved tests as specified by AS2047

Where the ultimate limit state wind pressure requirement exceed 6000Pa Please contact Wintec Systems for advice

S = Serviceability limit state wind pressure, U = Ultimate limit state wind pressure

$I_{xx} = 896.8 \times 10^3 \text{ mm}^4$
 $I_{yy} = 112.3 \times 10^3 \text{ mm}^4$



MULLION SPACING (CENTRES)
MAXIMUM PRESSURE (Pa)

		600	700	800	900	1000	1100	1200	1300	1400	1500
2000	S	4654	4110	3709	3403	3165	2976	2826	2705	2608	2532
	U	10000	10000	10000	9607	8934	8402	7977	7636	7363	7147
2100	S	3987	3515	3166	2899	2691	2525	2392	2284	2197	2126
	U	10000	10000	9385	8595	7977	7486	7091	6771	6512	6303
2200	S	3441	3029	2724	2491	2308	2162	2043	1947	1868	1804
	U	10000	9408	8460	7735	7166	6712	6345	6046	5801	5601
2300	S	2991	2630	2361	2156	1994	1865	1760	1673	1602	1544
	U	9711	8537	7667	6999	6474	6054	5712	5433	5202	5012
2400	S	2616	2297	2060	1878	1735	1620	1526	1449	1385	1332
	U	8863	7782	6980	6363	5878	5488	5170	4909	4692	4512
2500	S	2302	2019	1808	1647	1519	1416	1332	1263	1206	1157
	U	8122	7123	6381	5811	5360	4998	4702	4458	4254	4084
2600	S	2035	1783	1596	1452	1338	1246	1170	1108	1056	1012
	U	7470	6545	5857	5327	4909	4571	4295	4066	3875	3715
2700	S	1809	1583	1416	1286	1184	1101	1034	977	930	890
	U	6894	6034	5395	4902	4512	4197	3939	3725	3545	3394
2800	S	1615	1412	1261	1145	1053	979	917	867	824	788
	U	6381	5581	4986	4526	4162	3868	3626	3425	3256	3113
2900	S	1447	1265	1129	1024	941	873	818	772	733	700
	U	5924	5178	4621	4191	3851	3575	3349	3160	3001	2866
3000	S	1302	1137	1014	919	844	783	733	691	655	625
	U	5515	4816	4295	3893	3574	3315	3102	2924	2775	2647
3100	S	1176	1026	915	828	760	704	659	620	588	561
	U	5146	4491	4003	3625	3325	3082	2882	2715	2573	2453
3200	S	1066	929	828	749	687	636	594	559	530	505
	U	4814	4198	3739	3384	3102	2873	2685	2527	2393	2279
3300	S	969	844	752	680	623	576	538	506	479	456
	U	4512	3933	3501	3166	2901	2685	2507	2358	2231	2123
3400	S	883	769	684	619	566	524	489	459	435	413
	U	4238	3692	3285	2969	2718	2515	2346	2205	2085	1983
3500	S	807	703	625	565	517	478	445	418		
	U	3988	3473	3088	2790	2553	2360	2201	2067		
3600	S	740	644	572	517	473	437	407			
	U	3760	3273	2908	2626	2402	2219	2068			
3700	S	680	591	525	474	433	400				
	U	3551	3089	2744	2477	2264	2091				
3800	S	626	544	483	436						
	U	3359	2921	2593	2339						
3900	S	578	502	446	402						
	U	3182	2766	2454	2213						
4000	S	535	464	412							
	U	3018	2623	2327							

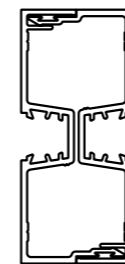

+ MULLION COMBINATION WASF4006/WASF4006
DEFLECTION LIMITED TO SPAN/250

These tables are based on theoretical section mechanical properties, not on approved tests as specified by AS2047

Where the ultimate limit state wind pressure requirement exceed 6000Pa Please contact Wintec Systems for advice

S = Serviceability limit state wind pressure, U = Ultimate limit state wind pressure

$I_{xx} = 1140.4 \times 10^3 \text{ mm}^4$
 $I_{yy} = 94.1 \times 10^3 \text{ mm}^4$



MULLION SPACING (CENTRES)
MAXIMUM PRESSURE (Pa)

		600	700	800	900	1000	1100	1200	1300	1400	1500
2000	S	5925	5232	4721	4332	4029	3789	3597	3443	3320	3223
	U	10000	10000	10000	10000	10000	10000	10000	9722	9374	9099
2100	S	5075	4475	4030	3691	3426	3215	3045	2908	2797	2707
	U	10000	10000	10000	10000	10000	9530	9027	8620	8290	8024
2200	S	4381	3857	3468	3171	2938	2752	2601	2479	2378	2296
	U	10000	10000	10000	9848	9124	8546	8078	7697	7386	7131
2300	S	3808	3348	3006	2744	2539	2374	2240	2130	2040	1965
	U	10000	10000	9760	8910	8242	7707	7272	6916	6623	6381
2400	S	3331	2925	2623	2391	2209	2062	1943	1845	1763	1696
	U	10000	9908	8886	8101	7483	6987	6582	6250	5974	5745
2500	S	2930	2570	2302	2096	1934	1803	1696	1608	1535	1473
	U	10000	9069	8124	7398	6824	6363	5986	5675	5416	5200
2600	S	2591	2270	2032	1848	1703	1586	1490	1411	1344	1289
	U	9510	8333	7457	6782	6250	5820	5468	5177	4934	4729
2700	S	2303	2016	1802	1637	1507	1402	1316	1244	1184	1134
	U	8776	7683	6868	6241	5745	5344	5015	4742	4514	4321
2800	S	2056	1798	1606	1458	1341	1246	1168	1103	1049	1003
	U	8124	7106	6347	5762	5299	4924	4616	4360	4145	3963
2900	S	1843	1610	1437	1304	1198	1112	1041	983	933	891
	U	7543	6592	5883	5336	4903	4552	4263	4023	3820	3648
3000	S	1658	1448	1291	1170	1074	997	933	879	834	796
	U	7021	6132	5468	4956	4550	4220	3949	3723	3532	3370
3100	S	1497	1307	1165	1055	967	897	838	790	749	714
	U	6552	5718	5096	4615	4234	3924	3669	3456	3276	3123
3200	S	1357	1183	1054	954	874	810	757	712	674	642
	U	6128	5345	4760	4308	3949	3658	3418	3217	3047	2902
3300	S	1233	1075	957	865	793	734	685	644	610	580
	U	5745	5007	4457	4031	3693	3418	3191	3001	2841	2703
3400	S	1124	979	871	788	721	667	622	585	553	526
	U	5396	4701	4182	3780	3461	3201	2987	2807	2655	2525
3500	S	1028	895	796	719	658	608	567	533	503	478
	U	5078	4421	3931	3552	3250	3004	2802	2631	2487	2363
3600	S	942	820	729	658	602	556	518	486	459	436
	U	4787	4166	3703	3343	3058	2825	2633	2472	2335	2217
3700	S	866	753	669	604	552	510	475	445	420	
	U	4521	3933	3493	3153	2882	2662	2479	2326	2196	
3800	S	797	693	615	555	507	468	436	409		
	U	4276	3718	3301	2978	2721	2512	2338	2193		
3900	S	736	640	568	512	467	431	401			
	U	4051	3521	3125	2818	2573	2374	2209			
4000	S	681	591	525	473	432					
	U	3843	3339	2962	2670	2437					

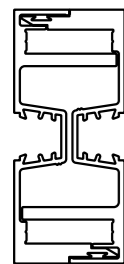

+ MULLION COMBINATION WASF4007/WASF4007
DEFLECTION LIMITED TO SPAN/250

These tables are based on theoretical section mechanical properties, not on approved tests as specified by AS2047

Where the ultimate limit state wind pressure requirement exceed 6000Pa Please contact Wintec Systems for advice

S = Serviceability limit state wind pressure, U = Ultimate limit state wind pressure

$I_{xx} = 2169.8 \times 10^3 \text{ mm}^4$
 $I_{yy} = 1140.4 \times 10^3 \text{ mm}^4$



MULLION SPACING (CENTRES)
MAXIMUM PRESSURE (Pa)

		600	700	800	900	1000	1100	1200	1300	1400	1500
2000	S	10000	9955	8983	8242	7665	7209	6844	6552	6318	6132
	U	10000	10000	10000	10000	10000	10000	10000	10000	10000	10000
2100	S	9657	8514	7669	7023	6518	6117	5794	5533	5321	5150
	U	10000	10000	10000	10000	10000	10000	10000	10000	10000	10000
2200	S	8336	7338	6599	6033	5590	5236	4949	4716	4525	4369
	U	10000	10000	10000	10000	10000	10000	10000	10000	10000	10000
2300	S	7245	6369	5720	5222	4830	4517	4262	4053	3881	3739
	U	10000	10000	10000	10000	10000	10000	10000	10000	10000	10000
2400	S	6337	5564	4991	4550	4203	3924	3697	3510	3355	3226
	U	10000	10000	10000	10000	10000	10000	10000	10000	10000	10000
2500	S	5575	4890	4380	3989	3679	3431	3228	3060	2920	2803
	U	10000	10000	10000	10000	10000	10000	10000	10000	10000	9893
2600	S	4930	4320	3866	3516	3240	3017	2835	2684	2558	2452
	U	10000	10000	10000	10000	10000	10000	10000	9850	9387	8998
2700	S	4381	3835	3429	3116	2868	2668	2504	2367	2253	2157
	U	10000	10000	10000	10000	10000	10000	9542	9023	8588	8221
2800	S	3911	3421	3055	2774	2551	2370	2222	2099	1995	1908
	U	10000	10000	10000	10000	10000	9368	8783	8296	7887	7540
2900	S	3506	3064	2734	2480	2279	2116	1981	1870	1776	1696
	U	10000	10000	10000	10000	9328	8660	8111	7654	7268	6942
3000	S	3155	2755	2457	2227	2044	1896	1774	1673	1587	1514
	U	10000	10000	10000	9430	8656	8030	7514	7084	6721	6412
3100	S	2849	2486	2216	2007	1841	1706	1595	1503	1424	1358
	U	10000	10000	9696	8781	8055	7466	6981	6575	6233	5941
3200	S	2581	2251	2005	1815	1664	1541	1440	1355	1283	1222
	U	10000	10000	9057	8197	7514	6960	6503	6120	5797	5521
3300	S	2346	2045	1820	1647	1508	1396	1304	1226	1160	1104
	U	10000	9527	8480	7670	7026	6504	6072	5711	5405	5143
3400	S	2139	1864	1658	1499	1372	1269	1184	1113	1053	1001
	U	10000	8944	7956	7192	6584	6091	5683	5341	5052	4804
3500	S	1955	1703	1514	1368	1252	1157	1079	1013	958	910
	U	9661	8412	7480	6757	6183	5716	5330	5007	4732	4497
3600	S	1792	1560	1386	1252	1145	1058	986	925	874	830
	U	9108	7927	7045	6361	5817	5375	5009	4702	4442	4218
3700	S	1647	1433	1273	1149	1050	970	903	847	800	759
	U	8601	7483	6646	5999	5483	5064	4717	4425	4178	3965
3800	S	1517	1319	1171	1056	965	891	829	778	734	696
	U	8136	7074	6281	5667	5177	4779	4449	4172	3937	3734
3900	S	1400	1217	1080	974	889	821	764	716	675	640
	U	7707	6699	5945	5361	4896	4517	4204	3940	3716	3523
4000	S	1295	1125	998	900	821	757	705	660	622	590
	U	7311	6352	5636	5080	4637	4277	3978	3727	3513	3329

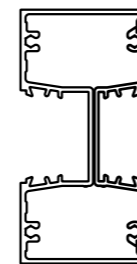

+ MULLION COMBINATION WASF4200/WASF4203
DEFLECTION LIMITED TO SPAN/250

These tables are based on theoretical section mechanical properties, not on approved tests as specified by AS2047

Where the ultimate limit state wind pressure requirement exceed 6000Pa Please contact Wintec Systems for advice

S = Serviceability limit state wind pressure, U = Ultimate limit state wind pressure

$I_{xx} = 1000.8 \times 10^3 \text{ mm}^4$
 $I_{yy} = 150.5 \times 10^3 \text{ mm}^4$



MULLION SPACING (CENTRES)
MAXIMUM PRESSURE (Pa)

		600	700	800	900	1000	1100	1200	1300	1400	1500
2000	S	5199	4592	4143	3802	3536	3325	3157	3022	2914	2829
	U	10000	10000	10000	10000	9981	9387	8912	8531	8226	7985
2100	S	4454	3927	3537	3239	3006	2821	2672	2552	2454	2376
	U	10000	10000	10000	9602	8912	8363	7922	7564	7275	7042
2200	S	3845	3385	3044	2783	2578	2415	2283	2175	2087	2015
	U	10000	10000	9452	8642	8006	7499	7089	6755	6481	6258
2300	S	3342	2938	2638	2409	2228	2083	1966	1870	1790	1725
	U	10000	9538	8565	7819	7233	6763	6382	6070	5812	5600
2400	S	2923	2567	2302	2099	1938	1810	1705	1619	1547	1488
	U	9902	8695	7798	7109	6567	6131	5776	5484	5242	5041
2500	S	2571	2255	2020	1840	1697	1582	1489	1411	1347	1293
	U	9074	7959	7130	6492	5989	5584	5253	4980	4753	4563
2600	S	2274	1992	1783	1622	1494	1392	1308	1238	1180	1131
	U	8346	7312	6544	5952	5484	5107	4799	4543	4330	4150
2700	S	2021	1769	1582	1437	1323	1230	1155	1092	1039	995
	U	7702	6742	6027	5477	5041	4689	4401	4161	3961	3792
2800	S	1804	1578	1409	1279	1176	1093	1025	968	920	880
	U	7130	6236	5570	5056	4650	4321	4051	3826	3638	3478
2900	S	1617	1413	1261	1144	1051	976	914	862	819	782
	U	6619	5785	5163	4683	4302	3994	3741	3530	3352	3202
3000	S	1455	1271	1133	1027	943	875	818	772	732	698
	U	6161	5381	4799	4349	3993	3704	3466	3267	3100	2957
3100	S	1314	1147	1022	926	849	787	736	693	657	626
	U	5750	5018	4472	4050	3715	3444	3220	3033	2875	2740
3200	S	1191	1038	925	837	767	711	664	625	592	564
	U	5378	4690	4177	3781	3466	3210	2999	2823	2674	2546
3300	S	1082	943	840	759	696	644	601	565	535	509
	U	5041	4394	3911	3538	3241	3000	2801	2634	2493	2372
3400	S	987	860	765	691	633	585	546	513	485	462
	U	4735	4125	3670	3317	3037	2809	2621	2464	2330	2216
3500	S	902	785	698	631	577	534	498	467	442	420
	U	4456	3880	3450	3117	2852	2636	2458	2309	2183	2074
3600	S	827	720	639	577	528	488	455	427	403	
	U	4201	3656	3249	2934	2683	2479	2310	2169	2049	
3700	S	760	661	587	530	484	447	417			
	U	3967	3451	3066	2767	2529	2336	2176			
3800	S	700	608	540	487	445	411				
	U	3752	3263	2897	2614	2388	2204				
3900	S	646	561	498	449	410					
	U	3555	3090	2742	2473	2258					
4000	S	597	519	460	415						
	U	3372	2930	2599	2343						

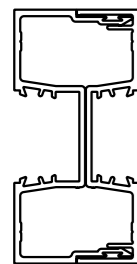

+ MULLION COMBINATION WASF4206/WASF4207
DEFLECTION LIMITED TO SPAN/250

These tables are based on theoretical section mechanical properties,
not on approved tests as specified by AS2047

Where the ultimate limit state wind pressure requirement exceed 6000Pa
Please contact Wintec Systems for advice

S = Serviceability limit state wind pressure, U = Ultimate limit state wind pressure

$I_{xx} = 1315.2 \times 10^3 \text{ mm}^4$
 $I_{yy} = 130.7 \times 10^3 \text{ mm}^4$

MULLION SPACING (CENTRES)
MAXIMUM PRESSURE (Pa)

		600	700	800	900	1000	1100	1200	1300	1400	1500
2000	S	6833	6034	5445	4996	4646	4370	4149	3971	3829	3717
	U	10000	10000	10000	10000	10000	10000	10000	10000	10000	10000
2100	S	5853	5160	4648	4257	3951	3708	3512	3354	3225	3122
	U	10000	10000	10000	10000	10000	10000	10000	9941	9561	9254
2200	S	5053	4448	4000	3657	3388	3174	3000	2859	2743	2648
	U	10000	10000	10000	10000	10000	9855	9316	8877	8518	8224
2300	S	4392	3861	3467	3165	2928	2738	2583	2457	2353	2267
	U	10000	10000	10000	10000	9505	8888	8387	7976	7638	7359
2400	S	3841	3373	3025	2758	2547	2378	2241	2127	2034	1956
	U	10000	10000	10000	9343	8630	8057	7591	7207	6889	6625
2500	S	3379	2964	2655	2418	2230	2079	1956	1855	1770	1699
	U	10000	10000	9369	8531	7870	7338	6904	6545	6246	5996
2600	S	2988	2618	2343	2131	1964	1829	1718	1627	1550	1486
	U	10000	9610	8599	7822	7207	6712	6306	5970	5690	5454
2700	S	2656	2325	2078	1888	1738	1617	1518	1435	1366	1307
	U	10000	8860	7921	7197	6625	6163	5784	5469	5205	4983
2800	S	2371	2073	1852	1681	1546	1437	1347	1272	1209	1156
	U	9369	8195	7320	6645	6110	5678	5323	5028	4780	4570
2900	S	2125	1857	1657	1503	1381	1282	1201	1133	1076	1028
	U	8698	7602	6785	6154	5654	5249	4916	4639	4406	4208
3000	S	1912	1670	1489	1350	1239	1149	1076	1014	962	918
	U	8097	7071	6306	5716	5247	4867	4555	4294	4074	3887
3100	S	1727	1507	1343	1216	1116	1034	967	911	863	823
	U	7556	6594	5877	5322	4882	4525	4231	3986	3778	3601
3200	S	1565	1365	1215	1100	1008	934	873	821	778	741
	U	7067	6164	5490	4969	4555	4219	3941	3710	3514	3346
3300	S	1422	1240	1103	998	914	846	790	743	703	669
	U	6625	5775	5140	4649	4259	3942	3680	3461	3276	3118
3400	S	1297	1130	1005	908	832	769	718	675	638	607
	U	6223	5421	4822	4359	3991	3692	3445	3237	3062	2912
3500	S	1185	1032	918	829	759	701	654	614	581	552
	U	5856	5099	4534	4096	3748	3465	3231	3035	2868	2726
3600	S	1086	946	840	759	694	641	598	561	530	503
	U	5521	4805	4270	3856	3526	3258	3036	2850	2692	2557
3700	S	998	868	771	696	636	588	547	514	485	460
	U	5213	4535	4029	3636	3324	3069	2859	2682	2532	2403
3800	S	919	799	710	640	585	540	503	471	445	422
	U	4931	4288	3807	3435	3138	2897	2697	2529	2386	2264
3900	S	849	738	655	590	539	497	463	434	409	
	U	4671	4060	3604	3250	2968	2738	2548	2388	2252	
4000	S	785	682	605	545	498	459	427	400		
	U	4431	3850	3416	3079	2811	2592	2411	2259		



MULLION HEIGHT

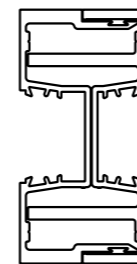

+ MULLION COMBINATION WASF4208/WASF4209
DEFLECTION LIMITED TO SPAN/250

These tables are based on theoretical section mechanical properties,
not on approved tests as specified by AS2047

Where the ultimate limit state wind pressure requirement exceed 6000Pa
Please contact Wintec Systems for advice

S = Serviceability limit state wind pressure, U = Ultimate limit state wind pressure

$I_{xx} = 2232.7 \times 10^3 \text{ mm}^4$
 $I_{yy} = 274.3 \times 10^3 \text{ mm}^4$

MULLION SPACING (CENTRES)
MAXIMUM PRESSURE (Pa)

		600	700	800	900	1000	1100	1200	1300	1400	1500
2000	S	10000	10000	9243	8481	7888	7418	7043	6742	6501	6310
	U	10000	10000	10000	10000	10000	10000	10000	10000	10000	10000
2100	S	9937	8760	7891	7227	6707	6294	5962	5693	5475	5300
	U	10000	10000	10000	10000	10000	10000	10000	10000	10000	10000
2200	S	8577	7551	6790	6208	5752	5387	5093	4853	4656	4496
	U	10000	10000	10000	10000	10000	10000	10000	10000	10000	10000
2300	S	7455	6554	5886	5373	4970	4647	4385	4171	3994	3848
	U	10000	10000	10000	10000	10000	10000	10000	10000	10000	10000
2400	S	6521	5726	5135	4682	4324	4038	3804	3612	3452	3320
	U	10000	10000	10000	10000	10000	10000	10000	10000	10000	10000
2500	S	5736	5031	4507	4104	3786	3530	3321	3149	3005	2885
	U	10000	10000	10000	10000	10000	10000	10000	10000	10000	10000
2600	S	5073	4445	3978	3618	3334	3105	2917	2762	2632	2523
	U	10000	10000	10000	10000	10000	10000	10000	10000	9659	9259
2700	S	4508	3946	3528	3206	2951	2745	2576	2436	2319	2219
	U	10000	10000	10000	10000	10000	10000	9818	9284	8837	8459
2800	S	4024	3520	3144	2854	2625	2439	2287	2160	2053	1963
	U	10000	10000	10000	10000	10000	9640	9037	8536	8115	7759
2900	S	3607	3153	2814	2552	2345	2177	2039	1924	1827	1745
	U	10000	10000	10000	10000	9598	8911	8346	7876	7479	7143
3000	S	3246	2835	2528	2291	2103	1951	1826	1721	1633	1558
	U	10000	10000	10000	9703	8907	8263	7732	7289	6916	6598
3100	S	2931	2558	2280	2065	1894	1756	1642	1546	1466	1397
	U	10000	10000	9977	9036	8288	7683	7183	6766	6414	6113
3200	S	2656	2317	2063	1867	1712	1585	1481	1394	1320	1258
	U	10000	10000	9320	8435	7732	7162	6691	6298	5965	5681
3300	S	2414	2105	1873	1694	1552	1437	1341	1261	1194	1136
	U	10000	9803	8726	7892	7230	6692	6248	5876	5561	5292
3400	S	2201	1918	1706	1542	1412	1306	1218	1145	1083	1030
	U	10000	9203	8187	7400	6775	6267	5848	5496	5198	4943
3500	S	2012	1752	1558	1407	1288	1191	1110	1043	986	937
	U	9941	8656	7696	6953	6362	5882	5485	5152	4869	4627
3600	S	1844	1605	1426	1288	1178	1088	1014	952	899	854
	U	9372	8157	7249	6546	5986	5531	5155	4839	4571	4341
3700	S	1695	1474	1309	1182	1080	998	929	872	823	781
	U	8851	7699	6839	6173	5642	5211	4854	4554	4299	4080
3800	S	1561	1357	1205	1087	993	917	853	800	755	716
	U	8371	7280	6463	5831	5327	4917	4578	4293	4051	3843
3900	S	1441	1252	1111	1002	915	844	786	736	695	659
	U	7930	6893	6118	5517	5038	4648	4326	4054	3823	3625
4000	S	1332	1158	1027	926	845	779	725	679	640	607
	U	7523	6537	5799	5227	4772	4401	4093	3835	3615	3426

MULLION HEIGHT

+ TRANSOM COMBINATION WASF4001/WASF4003
DEFLECTION LIMITED TO SPAN/250

These tables are based on theoretical section mechanical properties,
not on approved tests as specified by AS2047

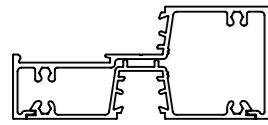

S = Serviceability limit state wind pressure, U = Ultimate limit state wind pressure
Stack Height = highlight and lowlight heights.

Maximum stress using 6063-T6 alloy limited to 190MPa

$I_{xx} = 1586.1 \times 10^3 \text{ mm}^4$
 $I_{yy} = 8104.6 \times 10^3 \text{ mm}^4$



TRANSOM WIDTH (mm)

				900	1000	1200	1500	1800	2100	2400
2100	1200	S	8000	8000	8000	7346	3891	2310	1484	
	900	U	8000	8000	8000	8000	8000	6512	4781	
2100	1500	S	8000	8000	8000	8062	4174	2444		
	600	U	8000	8000	8000	8000	8000	6889		
2400	1500	S	8000	8000	8000	7186	3702	2162		
	900	U	8000	8000	8000	8000	8000	6094		
2400	1800	S	8000	8000	8000	8062	4099	2342		
	600	U	8000	8000	8000	8000	8000	6602		
2700	1800	S	8000	8000	8000	7186	3644	2082		
	900	U	8000	8000	8000	8000	8000	5869		
3000	1800	S	8000	8000	8000	6746	3376	1916		
	1200	U	8000	8000	8000	8000	8000	5402		
2700	2100	S	8000	8000	8000	8062	4099			
	600	U	8000	8000	8000	8000	8000			
3000	2100	S	8000	8000	8000	7186	3644			
	900	U	8000	8000	8000	8000	8000			
3000	2400	S	8000	8000	8000	8000	4099			
	600	U	8000	8000	8000	8000	8000			
Maximum Glass Weight (kg)			130	130	130	130	75	50	33	

Deflection due to weight of glass limited to 5mm with setting blocks at span: 0.125 from each end

+ TRANSOM COMBINATION WASF4201/WASF4203
DEFLECTION LIMITED TO SPAN/250

These tables are based on theoretical section mechanical properties,
not on approved tests as specified by AS2047

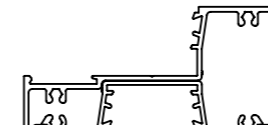

S = Serviceability limit state wind pressure, U = Ultimate limit state wind pressure
Stack Height = highlight and lowlight heights.

Maximum stress using 6063-T6 alloy limited to 190MPa

$I_{xx} = 1467.2 \times 10^3 \text{ mm}^4$
 $I_{yy} = 8729.6 \times 10^3 \text{ mm}^4$



TRANSOM WIDTH (mm)

				900	1000	1200	1500	1800	2100	2400
2100	1200	S	8000	8000	8000	7725	4091	2429	1561	
	900	U	8000	8000	8000	8000	8000	6624	4863	
2100	1500	S	8000	8000	8000	8000	4839	2570		
	600	U	8000	8000	8000	8000	8000	7008		
2400	1500	S	8000	8000	8000	7557	3893	2274		
	900	U	8000	8000	8000	8000	8000	6199		
2400	1800	S	8000	8000	8000	8000	4311	2463		
	600	U	8000	8000	8000	8000	8000	6716		
2700	1800	S	8000	8000	8000	7557	3832	2189		
	900	U	8000	8000	8000	8000	8000	5970		
3000	1800	S	8000	8000	8000	2094	3550	2015		
	1200	U	8000	8000	8000	8000	8000	5495		
2700	2100	S	8000	8000	8000	8000	4311			
	600	U	8000	8000	8000	8000	8000			
3000	2100	S	8000	8000	8000	7557	3832			
	900	U	8000	8000	8000	8000	8000			
3000	2400	S	8000	8000	8000	8000	4311			
	600	U	8000	8000	8000	8000	8000			
Maximum Glass Weight (kg)			180	180	180	180	106	67	45	

Deflection due to weight of glass limited to 5mm with setting blocks at span: 0.125 from each end



COFFEEBAR
GASTOWN

wintec systems

SINCE OUR BEGINNING IN 1997, WE HAVE DEVELOPED A RANGE OF WINDOW AND DOOR PRODUCTS THAT ARE INNOVATIVE, FUNCTIONAL AND STYLISH.

Wintec Systems windows and doors are an all Australian designed and manufactured product, with modern designs and quality finish at the forefront of the Wintec philosophy.

An ongoing commitment to product development and service to our Australia wide fabricator base ensures that no matter where you are, you have access to the latest designs in the Window and Door industry.

CENTRE GLAZED FRAMING FEATURES/ BENEFITS

Centre Glazed Framing Profiles are easy to manufacture and have a flexible range of uses.

Our 101.6mm framing integrates with our other Wintec architectural systems and our Sub-frame options ensure suitability for various applications both commercial and residential.

Options for both single and double glazing pockets allow for a wide range of glazing from 5mm to 28mm thickness and our 6063 T6 alloy improves the fabrication processes and overall product strength.

With the addition of colour coded glazing wedges, our systems become even easier to identify and select, and to top it off, our secure fit captive wedge improves retention in the glazing pocket.

**“ BUILDING PRODUCTS
BEYOND THE STANDARDS ”**

WINDOW & DOOR TESTING LABORATORY

The Wintec designed products are tested to Australian standard AS2047 in NATA accredited laboratory No 14093. This ensures your windows and doors comply with the building code of Australia [BCA] and are suited to your particular location. In line with the BCA requirements Wintec windows and doors carry a 7 year guarantee.

www.wintecsystems.com.au | 1800 WINTEC (1800 946 832)



AUSTRALIAN
**GLASS &
WINDOW**
ASSOCIATION



WORLD RECOGNISED
ACCREDITATION

